

Prepared by JAXA
Agenda Item: C.3
Discussed in Plenary

Status of Greenhouse gases Observing Satellite (GOSAT)

This document reports on an overview and the status of JAXA's
Greenhouse gases Observing Satellite (GOSAT)

1. Introduction

The Greenhouse gases Observing Satellite (GOSAT) is a satellite to monitor the carbon dioxide (CO₂) and the methane (CH₄) globally from orbit, and it aims to contribute to the international efforts to prevent global warming, such as the Kyoto Protocol. It is a joint project of Japan Aerospace Exploration Agency (JAXA), the Ministry of Environment (MOE) and National Institute for Environmental Studies (NIES). JAXA is responsible for satellite development, launch, and satellite operation. JAXA and MOE are in charge of the sensor development. MOE and NIES are responsible for satellite data utilization. It is scheduled to be launched in August, 2008.

2. GOSAT Mission Objectives

The objectives of the GOSAT mission are to contribute to environmental administration by estimating the Green House Gases (GHGs) source and sink in Sub-continental scale and verifying the reduction of GHG's emission which is required by the Kyoto Protocol and to advance earth observation technologies for future missions.

The targets of the mission are observation of CO₂ density in 3-month average with 1% (4ppmv) relative accuracy in sub-continental spatial resolution during the first commitment period (2008 to 2012) of the Kyoto Protocol and reducing errors by half in identifying the GHGs source and sink in Sub-continental scale with the data obtained by GOSAT in conjunction with the data gathered by the ground instruments.

Other applications of GOSAT are to provide earth radiation data with high spectral resolution, to monitor the CH₄ gas leak distribution from the pipeline etc..

3. Satellite

GOSAT is a medium-size satellite which weighs 1650 kg. It will be launched by H-IIA rocket of JAXA in 2008. Fig. 1 illustrates the GOSAT spacecraft and sensors. Table 1 shows the summary of the GOSAT satellite. GOSAT will be placed in a 666 km sun-synchronous orbit of 13:00 local time, with an inclination angle of 98 deg.

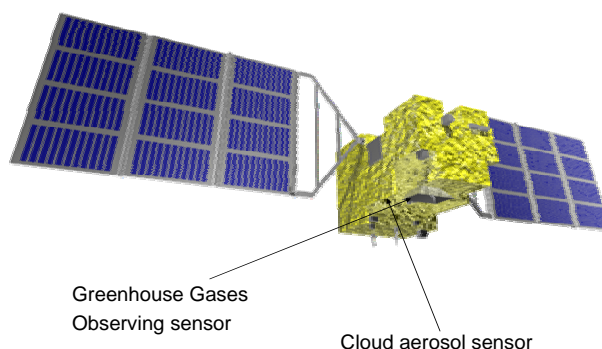

Fig. 1. The GOSAT satellite and sensors.

Table 1. The GOSAT satellite characteristics.

Size	Main body	2.6 x 2.4 x 3.7 m
Mass	Total	1650kg
Power	Total	4040 W
Life Span		5 years
Orbit	Sun Synchronous	
	Altitude	666 km
	Inclination	98 deg
	Local time	13:00 +/- 0:15
	Revisit	3 days
Launch	Vehicle	H-IIA
	Schedule	Augst.2008

4. GOSAT Onboard Sensors

4.1 TANSO-FTS

TANSO-FTS (Thermal And Near infrared Sensor for carbon Observations - Fourier Transform Spectrometer), which is to be accommodated on GOSAT, is a Fourier Transform Spectrometer (FTS) with high optical throughput and spectral resolution. Table 2 shows the specification of the TANSO-FTS and Fig. 2 illustrates the instrument outer structure. Fig. 3 also shows the optical layout, which consist of the pointing mechanism, relay optics, FTS, and detectors. The two axes redundant pointing mechanism can view the earth's surface, deep space, blackbody, and diffusers. The FTS optics and the optics of the band separation and detector are illustrated in Fig. 4 and Fig. 5, respectively. The FTS is a double pendulum type interferometer with two corner cube reflectors, and it covers from 0.76 to 15 micron with a ZnSe beam splitter and the

fully redundant 1.31 micron DFB laser sampling system is applied. The modulated light by the FTS is divided into four spectral bands with diachronic filters. Then, the SWIR bands lights are divided into two detectors with the polarization beam splitters. The InGaAs detectors are cooled with thermo-electric coolers. The TIR light is collected on the HgCdTe (MCT) detector, which is cooled with the pulse tube cooler. The small camera is also installed on the optical bench to register the FTS instantaneous field of view.

Table 2. The specification of TANSO-FTS.

Ground Pointing Mechanism and Fore optics	Configuration	2-axes scanner (fully redundant)			
	Scanning	Cross Track (± 35 deg) Along Track (± 20 deg)			
	Field of view	IFOV < 10.5 km 790 km (scan width) (latitude of 30 deg)			
Fourier Transform Spectrometer	Speed	0.25, 0.5, 1 (Interferogram)/sec			
	Spectral band	1		Spectral band	1
	Coverage (cm ⁻¹)	12900-13200		Coverage (cm ⁻¹)	12900-13200
	Resolution (cm ⁻¹)	0.2 cm ⁻¹ (both sides) (MOPD ± 2.5 cm)			
	Detector	Si		Detector	Si
	Calibration	Solar Irradiance, Deep Space, Moon, Diode laser			

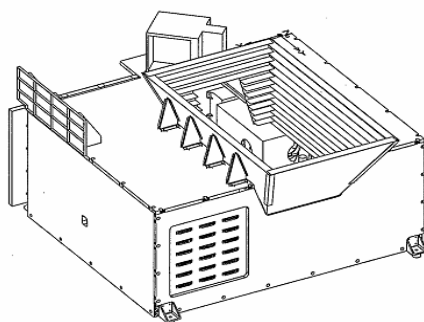

Fig. 2. The outer structure of TANSO-FTS

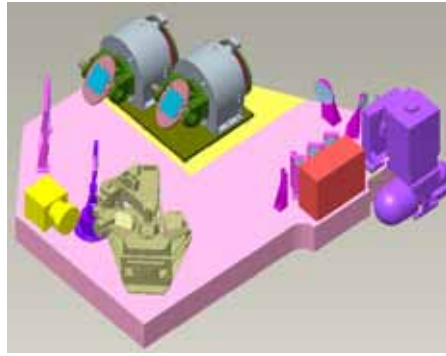

Fig. 3. The optical layout.

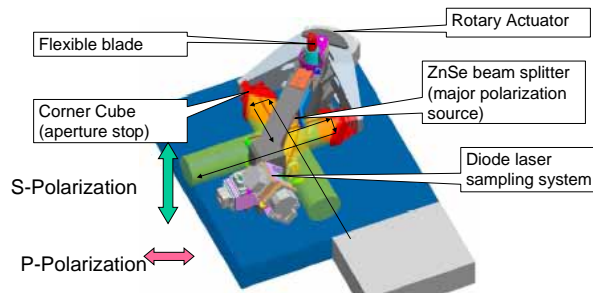

Fig. 4. The FTS optics.

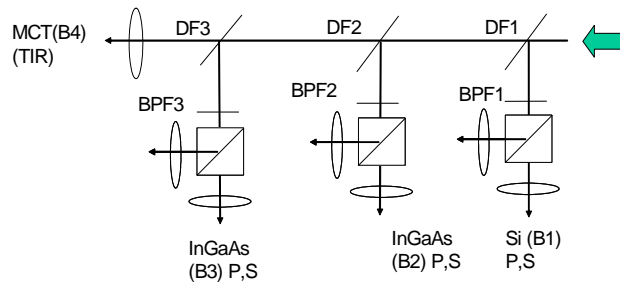

Fig. 5. The band separation optics and the detectors.

4.2 TANSO-CAI (Thermal And Near infrared Sensor for carbon Observations - Cloud and Aerosol Imager)

TANSO-CAI (Thermal And Near infrared Sensor for carbon Observations - Cloud and Aerosol Imager) to detect and correct the cloud and aerosol interference is also borne together with the TANSO-FTS. Table 3 shows the specification of the TANSO-CAI and Fig.6 illustrates the outer structure of the TANSO-CAI. The TANSO-CAI has continuous spatial coverage, wider field of view, and higher spatial resolution than the FTS in order to detect the aerosol spatial distribution and cloud coverage. Using the multi spectral bands, the spectral characteristics of the aerosol scattering can be retrieved together with optical thickness. In addition, the UV band data will provide the

aerosol data over the land. With the FTS spectra, imager data, and the retrieval algorithm to remove cloud and aerosol contamination, the column density of the gases can be retrieved with 1 % accuracy.

Table 3. The specification of TANSO-CAI.

	Band Center Wave length (μm)	Band width (nm)	Spatial Resolution (IFOV) (km)	No. of Pixels (cross track)
1	0.380	20	0.5	2000
2	0.674	20	0.5	2000
3	0.870	20	0.5	2000
4	1.60	90	1.5	500



Fig..6. The outer structure of TANSO-CAI

5. Sensor Operation

Fig..7 shows the concept of the greenhouse gases observation. During the day both SWIR and TIR of the FTS and the imager data are acquired, and at night only FTS TIR data is acquired. At the sunrise, the direct sun light is introduced into the FTS through the Spectral on diffuser plates for SWIR radiance calibration. Two diffusers with different exposure time are introduced to correct the long term diffuser degradation. In addition, the 1.55 micron diode laser light is introduced through the diffuser plate into the FTS to calibrate the instrument function onboard. The pointing mechanism views the deep space and inner blackbody periodically for the zero level and TIR radiance calibration.

By rotating the satellite, both the FTS and the imager can view the moon surface, which provides the stable radiance source. This lunar calibration is scheduled once a year. Fig..8 and Fig..9 show the geometry of nadir-looking measurements and the concept of the GOSAT altitude control and pointing system, respectively. The pointing system and the FTS can point the same ground mesh footprint in every 3 days. Over the ocean in low latitude, the pointing mechanism point the sun glint point, where specular reflection

occurs and reflectivity is high.

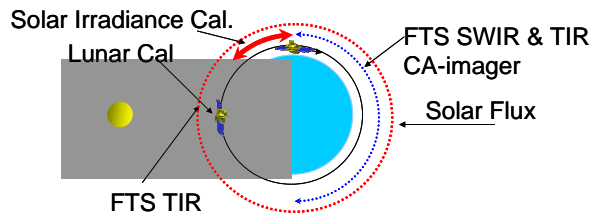

Fig..7. The GOSAT operation.

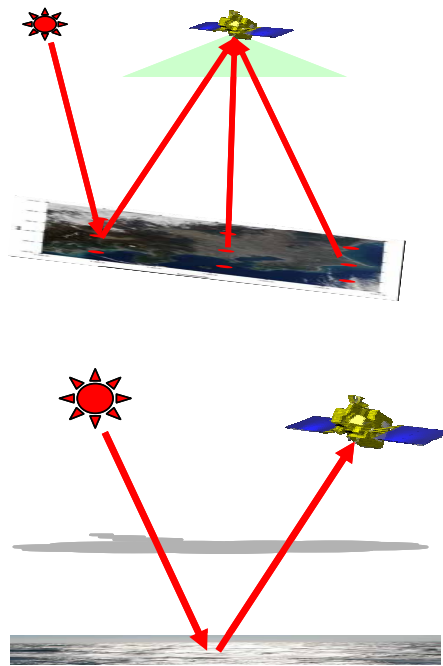

Fig..8. The image of (a) nominal observation and (b) sun glint observation.

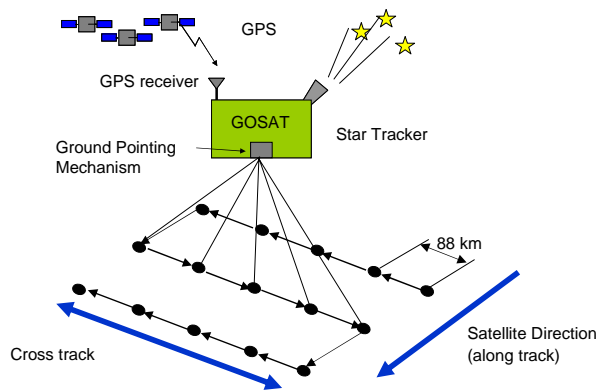

Fig..9. The concept of altitude control and ground pointing.