

CGMS-XXVII
Prepared by: W. Dorsey
Agenda Item:
USA WP-18 (part 1)

**Version 1: 300 / 1200 BPS GOES Data Collection Platform Radio Set
(DCPRS) CERTIFICATION STANDARDS (part 1)**

Action: CGMS is invited to accept proposed certification plan as a standard for CGMS Members (part 1 & 2)
--

Sent in 2 parts due to large file size.

TABLE OF CONTENTS

Introduction	page 1
Document Organization	page 1
SECTION 1 - DCPRS Certification Documentation Submission	page 2
SECTION 2 - DCPRS Data Rate and Operating Mode Requirements	page 2
2.1 Self-Timed Reporting Mode	page 2
2.2 Random Reporting Mode	page 3
2.3 Interrogate Reporting Mode	page 3
SECTION 3 - DCPRS Data Format Requirements	page 4
3.1 DCPRS Data Format	page 4
3.2 Data Scrambling	page 5
3.3 Convolutional or Trellis Encoding	page 5
3.4 Encoder Flush	page 6
3.5 DCPRS Interleaver Requirements	page 6
3.6 Modulation Encoding (N X 45 degrees, +/- 2.5 degrees)	page 7
3.7 DCPRS Data Formats	page 7
3.8 Maximum Message Length (MML)	page 8
3.9 Transmit Frequency Adjustment	page 8
SECTION 4 - DCPRS Performance Requirements	page 8
4.1 DCPRS Effective Isotropic Radiated Power (EIRP)	page 8
4.2 GOES DCS Operating Frequency Requirements	page 9
4.3 DCPRS Modulation Requirements Transmit Spectrum	page 9
4.4 DCPRS Phase Noise	page 10
4.5 DCPRS Transmit Spectrum	page 10
4.6 Fail-safe Operation	page 11

Appendices

Appendix A - Recommended Test Equipment and Set up	page 12
Appendix B - DCPRS Pseudo Binary and Other Definitions	page 16
Appendix C - Interrogate DCPRS Receive Requirements	page 20
Appendix D - GOES DCS Transmit Frequencies	page 21
Appendix E - GOES DCS Certification Notes	page 24
1.0 Carrier Phase Noise Test Loop	page 24
2.0 Transmitted Power	page 25
3.0 Phase Error Budget	page 25
4.0 Phase Measurement	page 26

GOES DCS 300/1200 BPS DCPRS CERTIFICATION STANDARDS FOR SELF-TIMED, RANDOM REPORTING, and INTERROGATE OPERATION

Introduction

DCPRS Certification is achieved by demonstrating that a radio set (transmitter and/or receiver) fulfills each of the requirements set forth in the respective portions of this document. NESDIS certification is "type certification", wherein a representative production unit is tested and found to fulfill all stated requirements. NESDIS certification of individual production units (those having the same model number) is not required. **As a standard, this document represents mandatory requirements--waivers will not be accepted.**

To obtain AType Acceptance@ the manufacturer shall submit the DCPRS schematics, data flow chart, electronics parts design data, unit and system test data, and perform tests to demonstrate that each requirement herein is met. This includes but is not limited to analysis of the DCPRS= design and performance characteristics, performing unit tests t room temperature, and over a range of temperature and power supply (battery voltage) variations. For clarity the certification requirements have been grouped into related areas. For example, all EIRP requirements are included in one section.

Certification testing shall be ran with standard laboratory test equipment and with a NOAA supplied Test Receiver/Demodulator. This test unit includes a computer output port from the demodulator for test data extraction points from the unit under test. The output port is accessed by the use of a Adumb@ terminal which is obtained by running a terminal emulation programs such as BitCom, ProComm, and etc. through an IBM type desktop or laptop PC. The test demodulator has other access points for AI@ and AQ@ phase detector measurements. Test guidelines, procedures, etc. are described in the appendix of this document. The NOAA Test Receiver/Demodulator will be loaned for a period of up to thirty days to manufacturer=s after the required documentation and design data requirements in Section 1 have been approved by the NOAA NESDIS Certification Official.

Manufacturer=s are required to supply all other test equipment needed to demonstrate compliance with the certification requirements. All test equipment to be used must be identified in the manufacturer=s initial request for DCP certification and have verified calibrations to an established test laboratory. A list of the recommended test equipment, a typical test set up, and some of the capabilities of the NOAA provided test set are included in Appendix A .

Document Organization

The GOES DCPRS certification requirements are set forth in the following four sections. The first section identifies the DCPRS certification documentation required. The second section defines the DCPRS= certification reporting mode requirements. The third section focuses upon the DCPRS transmit data format requirements which are not considered to be temperature dependent. The

fourth section involves requirements for which performance may vary over temperature and power supply variation such as output power, frequency stability, modulation stability, carrier phase noise, transmit spectrum, etc.

SECTION 1 - DCPRS Certification Documentation Requirements

Manufacturer=s shall submit the following documentation at least 60 days prior to beginning the formal DCPRS certification testing. While NESDIS may review and comment on this documentation, all documentation is considered >PROPRIETARY= for government eyes only and not available, unless so identified by the manufacturer, to any other party.

- a) DCPRS Model Number with its respective data and/or specification sheet(s)
- b) DCPRS electrical and electronic circuit schematics.
- c) DCPRS software flow-charts that identify how the DCPRS reporting method(s) - random, self-timed, interrogated, message formatting/generation, frequency and time stability functions, Fail-safe operation, other functions are fulfilled.
- 4) DCPRS antenna gain, polarization, axial ratio, and VSWR data. This data shall be used with the power amplifier output to determine the DCPRS EIRP (Equivalent Isotropic Radiated Power).
- 5) Manufacturers Proposed Test Procedures including test data sheets.
- f) DCPRS oscillator aging analysis data to demonstrate that the specified aging requirements are met.

SECTION 2 - DCPRS Data Rate and Operating Mode Requirements

For High Data Rate (HDR) operation a DCPRS may be designated for either 300 bps or for 1200 bps. Further the DCPRS manufacturer shall clearly state the reporting mode(s) for the Model/unit (i.e. Self-timed, Random, or Interrogate). A combination of two operating modes is permitted providing this is so identified and that all applicable mode requirements are met. The DCPRS certification official will identify specific channels, GOES ID/DCP Address, and time slots as needed for any >on-the-air= or >GOES testing.=

2.1 DCPRS Self- Timed Reporting Mode Requirements

All DCPRS designated for self-timed operations shall fulfill the timing requirements identified below.

2.1.1 300 BPS Reporting Time Accuracy

Manufacturer=s shall also demonstrate that self-timed reporting will have a drift of no more than ± 30 seconds per year. Manufacturer=s may use a combination of analysis with oscillator drift data and DCP software utilized.

The DCPRS shall be demonstrated to operate for 48 hours on a NOAA/NESDIS assigned channel and time slot. The timing accuracy shall not exceed a prorated ± 30 seconds per

year.

2.1.2. 1200 BPS Reporting Time Accuracy

All 1200 BPS DCPRS transmissions shall be within ± 0.5 seconds of the assigned reporting time with a probability of 99.9% within any one year period and at any temperature over a range of -40°C to $+50^{\circ}\text{C}$. This shall include any inaccuracies associated with the initial setting of the clock by the user as specified in paragraph 2.1.5 below.

2.1.3. DCPRS Time Reference

DCPRS reporting time shall always be with respect to Coordinated Universal Time (UTC).

2.1.4. Inhibiting Transmissions

Should that the DCPRS clock differs by more than ± 0.5 seconds from the Coordinated Universal Time (UTC) at time of transmission, transmission (including RF carrier) shall be inhibited (i.e. shall be canceled). After an inhibited transmission should the DCPRS clock be restored to less than ± 0.5 seconds from Coordinated Universal Time (UTC), the DCPRS may resume normal transmissions.

2.1.5. Setting and Verifying the DCPRS Clock

Manufacturer=s shall provided a method to enable a user to set the DCPRS clock to an accuracy of within ± 0.1 seconds of Coordinated Universal Time (UTC). The needed equipment and software must be available from the DCPRS vendor to verify the accuracy of the DCPRS clock after it has been set.

NOTE: The requirements in paragraphs 2.1.4 and 2.1.5 are mandatory for the 1200 BPS DCP and are optional for the 300 BPS DCP.

2.2. DCPRS Random Reporting Mode Requirements

For random reporting certification manufacturer=s shall demonstrate that the DCPRS transmits at a maximum message length of 3 seconds for 300 BPS and 1.5 seconds for 1200 BPS. The same algorithm and/or processes used for 100 bps certification may be used. Definitions of pseudo binary and other concepts are included in Appendix B. Random reporting certification testing requires that manufacturer=s demonstrate random message generation on an approved NESDIS channel and transmit DCP messages in the random mode for eight (8) or more hours with an average repeat interval of every 15 minutes. One of the data values to be transmitted in this testing shall be a message number counter.

2.3. DCPRS Interrogate Reporting Mode Requirements

Enhancement

Bit 4	Reed Solomon	on = 1, off = 0	Possible Future
-------	--------------	-----------------	-----------------

Enhancement

Bit 5	spare, undefined		
Bits 6 & 7	ASCII = 10, Pseudo Binary = 11, Binary = 01		
(MSB) Bit 8	Odd parity for ASCII formatted data		

The FSS consists of three possible 15 bit words where 0 degrees = A0" and 180 degrees= A1" or A0-1" at the symbol rate, the same as for the clock. The left most bit is transmitted first.

After the FSS is transmitted the remainder of the format is presented as eight (8) bit bytes. If an interleaver is enabled the respective FSS word shall be generated. After the FSS is transmitted the GOES ID and all data shall be scrambled, trellis encoded, and interleaved as defined in paragraph 3.5 below.

The GOES ID is a 31-bit Bose-Chaudhuri-Hocquenghem (BCH) address with a zero implied as the 32nd LSB. This address shall be transmitted as the first 4 bytes of the data in the message in exactly the same manner as all the other data bytes in the message. For example, given the hex ID of **CE 12 00 B8**, the first byte transmitted is **CE** hex, followed by **12** Hex, followed by **00** hex, followed by **B8** hex or **11001110 00010010 00000000 10111000**.

3.2 Data Scrambling

At the beginning of the GOES ID all DCP data must be scrambled. Each data byte is scrambled by Exclusive ORing (XOR) the byte with a byte from the following 40 byte table. The first byte is XORed with the first byte in the table (53 hex). The next byte is XORed with the second byte in the table (12 hex), and so on. After the 40th byte has been scrambled the next scramble byte to be used is the first byte (53 hex). The below table is to be used in a circular fashion throughout the message.

53	12	72	B2	54	62	AA	E4	DB	A7	56	08	A8	09	B4	BF	61	DC	50	E3
AB	7F	00	87	6D	F5	58	CC	CF	3E	E7	2A	7E	9B	5C	4D	CE	A5	3C	0A

This array is treated as a single binary string where each data binary pair generates one symbol. BAD hex is the first symbol output and recycles after 160 input symbols. This array shall be cycled through as many times as required for the duration of the message data.

3.3 Convolutional or Trellis Encoding

Figure 3 provides a Functional Block Diagram of the convolutional/Trellis encoder required. This

hardware logic generates the 3 tri-bits, which are used to generate each eight (8) PSK symbol to be modulated. Each data byte contains 8 bits. These bits are split into four 2 bit pairs as shown in the table below.

MSB			LSB
Bits 7 & 6	Bits 5 & 4	Bits 3 & 2	Bits 1 & 0
Bit Pair 4	Bit Pair 3	Bit Pair 2	Bit Pair 1

Each 2-bit pair is fed into the trellis encoder in order. Pair 1 is fed into the encoder, then pair 2, etc. The trellis encoder takes a 2-bit pair and encodes it to a 3-bit symbol. This 3-bit symbol is then mapped to one of the eight phases for transmission as shown in Table 3.6.

3.4 Encoder Flush

At the end of the message after transmitting the EOT an additional 16 zero (0) data bits shall be provided to flush the encoder. After the 16th flush bit is transmitted, the interleaver shall be unloaded (if used), the phase should be brought to zero and the carrier power shall be turned off.

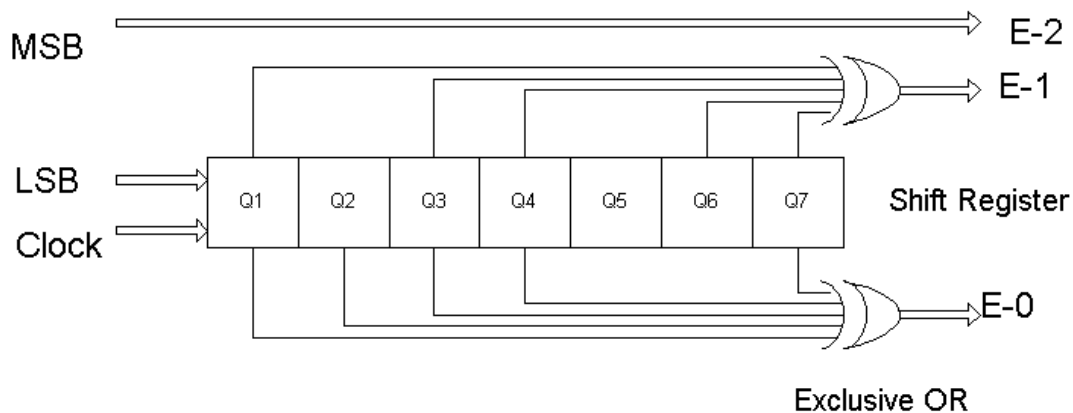

Fig. 3 TRELLIS ENCODER LOGIC

3.5 DCPRS Interleaver Requirements

The DCPRS shall contain two types of interleavers that are users selectable from the DCPR test menu. The type is identified by the MLS word selected. The interleavers compile the symbols to be sent into a matrix of fixed size. If the EOT and flush symbols do not fill out the interleaver matrix block then data zeros (0) shall be used to complete the data block.

Short interleaver. A data block which is 16 columns wide and 24 rows deep with a total of 384 symbol positions.

Long interleaver. A data block which is 24 columns wide and 32 rows deep with a total of 768 symbol positions.

3.5.1 Interleaver Loading

When the interleaver is enabled, the first symbol loaded shall be the first scrambled and encoded symbol of the GOES ID or DCPRS address word. The interleaver shall be loaded in a column major fashion. For example, the first symbol of the scrambled and encode BCH coded address word will be placed in column 1, row 1. The second symbol will be placed in column 1, row 2, until the first column is full. The next symbol will be placed in column 2, row 1, and so forth.

3.5.2 Loading the Last Interleaver of the Message

Once all the scrambled and encoded data (sensor, EOT, and any encoder flush bits) have been loaded into the interleaver, the DCPRS shall continue to input pairs of A0@s into the scrambler/encoder until the interleaver block is full.

3.5.3 Unloading the Interleaver

The interleaver shall be unloaded in a row major fashion. This means that the symbol in column 1, row 1 will be transmitted first, followed by the symbol in column 2, row 1. After the entire row has been transmitted, the DCP shall begin transmitting the symbols from row 2 in the same manner.

3.6 DCPRS Modulation Encoding (N X 45 degrees, +/- 2.5 degrees)

The transmitted data shall be phase mapped from the trellis encoder as shown in Table 3.6.

E-2 MSB	E-1 Bit	E-0 LSB	Phase Symbol Degrees
0	0	0	0
0	0	1	45
0	1	0	135
0	1	1	90
1	0	0	180

1	0	1	225
1	1	0	315
1	1	1	270

Table 3.6 Phase Encoding

3.7 DCPRS Data Formats

Three data formats shall be demonstrated ASCII, Pseudo Binary and Binary. HDR pseudo binary shall be the same as for 100 bps DCPRS certification (see Appendix B).

3.7.1 Prohibited Characters

For ASCII or Pseudo Binary format the following control characters are prohibited: DLE, NAK, SYN, ETB, CAN, GS, RS, SOH, STX, ETX, ENQ, ACK, and EOT. For DCPRS certification testing a set of five messages of at least 500 characters in length shall be sent in a pre-defined ASCII character set. The test demodulator output will be capable of extracting this transmitted text.

For binary mode certification a fixed set of binary values is sent five times. The string should be at least 256 bytes long. The precise format and error checking for HDR binary transmissions is TBD.

3.7.2 End Of Transmission (EOT)

ASCII and Pseudo Binary Format Mode - An EOT code word, bit pattern 00000100 - LSB first, shall be sent immediately after the last symbol of sensor data. This bit pattern is an ASCII EOT with odd parity.

Binary Mode - An (EOT) code word, bit pattern 1100011110010101110100000100 - LSB first, shall be sent immediately after the last symbol of sensor data. This bit pattern is identical to that required for international DCPRS certification.

3.8 DCPRS Maximum Message Length (MML)

The MML for any 300 bps or 1200 bps High Data Rate transmission shall be 126,000 bits (see paragraph 4.6 for DCPRS fail-safe requirements).

3.9 DCPRS Transmit Frequency Adjustment

The manufacturer shall demonstrate at room temperature that DCPRS output frequencies are adjustable to within 25 Hz of the nominal channel center frequency.

SECTION 4 - DCPRS Performance Requirements

DCPRS performance requirements shall be demonstrated over a -40° C to 50°C temperature range and over a power supply voltage variation of 15 per cent of nominal (i.e. 12 ± 1.8 volts).

4.1 DCPRS Effective Isotropic Radiated Power (EIRP)

4.1.1 RF Power Output

For 300 bps the DCPRS shall have a nominal EIRP of 48 dBm - Carrier only and a maximum EIRP of 50 dBm under any combination of power supply or temperature variation.

For 1200 bps the DCPRS shall have a nominal EIRP of 51 dBm - Carrier only and a maximum EIRP of 53 dBm under any combination of power supply or temperature variation.

Note: During the random modulation portion of the message the output power will be 1 dB less (See Appendix E paragraph 1- test notes for a discussion of RMS transmitted power).

4.1.2 DCPRS Antenna

4.1.2.1 Antenna Polarization

DCPRS antenna polarization shall be right-hand circular, according to IEEE Standard 65.34.159 and have an axial ratio or equal to or less than 6 dB on axis.

4.1.2.2 DCPRS Antenna Gain

The DCPRS antenna transmit gain shall be such that in combination with the DCP output power the maximum EIRP is not exceeded.

4.2 GOES DCS Operating Frequency Requirements

The GOES domestic DCS operates at UHF from 401.7 MHz to 402.0 MHz with either 200- 1.5 kHz channels @ 100/300 bps, 100 - 3.0 kHz channels @ 1200 bps or a combination thereof. The GOES international DCS operates from 402.0 MHz to 402.1 MHz with 33-3kHz channels. Although the 300 bps and 1200 bps DCPRS has not been adopted or approved for use in the international DCS, 3 kHz tuning from 402.0 MHz to 402.1 MHz is required for all HDR DCPRS.

4.2.1 Operating Channels and Frequencies

The assigned DCPRS operating channels and frequencies for 300 bps and for 1200 bps operations are set forth in Appendix D. For certification testing manufacturer=s shall to demonstrate the synthesis of each of these over the entire range of the possible operation and at a minimum of five frequencies for 300 bps and five for 1200 bps selected at random by the NESDIS Certification Official.

4.2.2 Frequency Stability, Long Term

The DCPRS output frequency shall maintain a long term stability of ± 0.5 PPM per year under any combination of power supply variation or temperatures set forth in paragraph 4.0 on any channel frequency defined in Appendix D. The output frequency shall be maintained to within ± 225 Hz of the channel center.

4.2.3 Short Term Frequency Stability

The DCPRS output frequency shall maintain a short term stability of ± 1 Hz/s under any combination of power supply variation or temperature as set forth in paragraph 4.0. For certification testing the frequency shall be measured over 10 - ten second sample windows and the difference over 100 seconds shall be recorded.

4.3 DCPRS Modulation Requirements

4.3.1 Output Symbol Rate

For 300 bps certification the output symbol rate shall be 150 symbols per second $\pm 0.025\%$.

For 1200 bps certification the output symbol rate shall be 600 symbols per second $\pm 0.025\%$.

For certification testing the DCPRS is to be set to transmit 0.5 second of carrier and then a continuous stream of A0-1" or 0□ and 180□ clock transitions at the respective symbol rate. The symbol period is to be measured at the AI@ output of the test demodulator.

4.3.2 DCPRS 8-ary Modulator Stability

The 8-ary modulator shall maintain a stability/accuracy of $\leq \pm 2.5$ degrees under any combination of power supply or temperature variation as defined in paragraph 4.0 (See Appendix E - GOES DCS Certification Test Notes Paragraph 3.0 Phase Measurement).

4.4 DCPRS Phase Noise

4.4.1 DCPRS Carrier Phase Noise

The DCPRS carrier phase noise shall be < 2.5 degrees RMS under any combination of power supply or temperature variation as defined in paragraph 4.0.

DCPRS RMS phase noise is to be measured during transmission of carrier only. First the test set up residual noise from the receiver and signal generator shall be measured. This should be < 0.2 degrees. Then measure the DCPRS phase noise. Subtract the residual set up phase noise from the DCPRS phase noise.

The DCPRS phase noise measurement is to be made at the AQ@ output of the test demodulator. While making this measurement the test signal should be observed on an oscilloscope. Test data can be extracted from the test demodulator program or by using RMS voltmeter with a 2000 Hz

response at the 1200 BPS data rate.

4.4.2 DCPRS Dynamic Phase Noise (Inter Symbol Interference (ISI))

The DCPRS dynamic phase noise or ISI shall be ≤ 1.5 degrees RMS (see Appendix E - GOES DCS Certification Test Notes Para. 2.0 Phase Error Budget) which provides a recommended measurement process.

4.5 DCPRS Transmit Spectrum

The SA set up parameters (Resolution Bandwidth (RBW), video filtering, etc.) shall be established by the manufacturer and test data furnished per Section 1 of the certification documentation requirements.

4.5.1 Narrow Band Transmit Spectrum

For narrow band transmit spectrum measurement data shall be taken using a continuous clock (0° to 180°) of pulses and a random data pattern at the 300 bps or 1200 bps data rate. These measurements shall be taken as dB down from the envelop peak and not dBc. It should be noted that data taken with the A0-1" provides a well defined output. While the random 8 psk data is not as well defined, its spectrum shall fulfill the requirements indicated below.

For the 300 bps Data Rate the Spectrum shall be as follows:

Frequency from Center	dB Down w/ A0-1" Clock	dB Down w/ Random Clock
$F_o \pm 225$ Hz	$\leq - 14$ dB	$\leq - 20$ dB
$F_o \pm 375$ Hz	$\leq - 18$ dB	$\leq - 26$ dB
$F_o \pm 525$ Hz	$\leq - 21$ dB	$\leq - 31$ dB
$F_o \pm 675$ Hz	$\leq - 24$ dB	$\leq - 36$ dB
$F_o \pm 825$ Hz	$\leq - 27$ dB	$\leq - 40$ dB
$F_o \pm 975$ Hz	$\leq - 30$ dB	$\leq - 44$ dB
$F_o \pm 1125$ Hz	$\leq - 32$ dB	$\leq - 46$ dB
$F_o \pm 1275$ Hz	$\leq - 34$ dB	$\leq - 47$ dB

$F_o \pm 1425 \text{ Hz}$	$\leq - 36 \text{ dB}$	$\leq - 48 \text{ dB}$
$F_o \pm 1575 \text{ Hz}$	$\leq - 38 \text{ dB}$	$\leq - 49 \text{ dB}$
$F_o \pm 1725 \text{ Hz}$	$\leq - 40 \text{ dB}$	$\leq - 51 \text{ dB}$

For the 1200 bps Data Rate the Spectrum shall be as follows:

Frequency from Center	dB Down w/ A0-1" Clock	dB Down w/ Random Clock
$F_o \pm 900 \text{ Hz}$	$\leq - 14 \text{ dB}$	$\leq - 20 \text{ dB}$
$F_o \pm 1500 \text{ Hz}$	$\leq - 18 \text{ dB}$	$\leq - 26 \text{ dB}$
$F_o \pm 2100 \text{ Hz}$	$\leq - 21 \text{ dB}$	$\leq - 31 \text{ dB}$
$F_o \pm 2700 \text{ Hz}$	$\leq - 24 \text{ dB}$	$\leq - 36 \text{ dB}$
$F_o \pm 3300 \text{ Hz}$	$\leq - 27 \text{ dB}$	$\leq - 40 \text{ dB}$
$F_o \pm 3900 \text{ Hz}$	$\leq - 30 \text{ dB}$	$\leq - 44 \text{ dB}$
$F_o \pm 4500 \text{ Hz}$	$\leq - 32 \text{ dB}$	$\leq - 46 \text{ dB}$
$F_o \pm 5100 \text{ Hz}$	$\leq - 34 \text{ dB}$	$\leq - 47 \text{ dB}$
$F_o \pm 5700 \text{ Hz}$	$\leq - 36 \text{ dB}$	$\leq - 48 \text{ dB}$
$F_o \pm 6300 \text{ Hz}$	$\leq - 38 \text{ dB}$	$\leq - 49 \text{ dB}$
$F_o \pm 6900 \text{ Hz}$	$\leq - 40 \text{ dB}$	$\leq - 51 \text{ dB}$

NOTE: See Appendix E Test Notes for plots of the above transmit spectrum.

4.5.2 Mid-Band Transmit Spectrum

With the transmitter set with a random 8 PSK modulation the Mid-Band and Harmonics shall be as set forth below:

For the 300 bps data rate at $F_o \geq \pm 1500 \text{ Hz}$ $\leq -60 \text{ dBc}$
 For the 1200 bps data rate at $F_o \geq \pm 10000 \text{ Hz}$ $\leq -60 \text{ dBc}$

4.5.3 Combined Spurious

The combined spurious within +/- 500 kHz of the carrier (excluding the modulation side bands) < -50 dBc. (This would be the equivalent to the sum of 10 side bands of B 60 dBc each.)

4.6 Fail-safe Operating Requirements

An independent or separate fail-safe circuit shall be provided to prevent a DCPRS from operating in an uncontrolled fashion. This independent circuit must Apermanently @ shut off the transmitter if any of two conditions are violated. These two conditions are:

- ! Message is too long. For 300 BPS a DCP message length of ≥ 270 seconds shall trip the fail-safe. For 1200 BPS a DCP message length of ≥ 105 seconds shall trip the fail safe.
- ! Message sent is too soon. There shall be a minimum of 60 seconds off-time between successive transmissions. If a second message is transmitted before 60 seconds has expired, then the fail-safe shall be tripped.

The fail-safe capability must be demonstrated for all conditions over the defined operating a -40° C to 50° C temperature range and over the required power supply voltage variation. Removal of DC power from the DCPRS shall not affect the operation of this function.

Note: The above term Apermanently@ requires a manual intervention or reset of the DCPRS in order to restore the unit for operational use in the DCS.

APPENDIX A - Recommended Test Equipment and Test Set Up

The following test equipment or approved equal are recommended:

Spectrum Analyzer (SA) - The SA is needed to perform for spectrum tests. The SA must be able to measure to the third harmonic at 1206 MHz with sufficient Resolution Bandwidth.

Frequency Meter (FM) - The FM is needed to measure transmit frequencies (401.7 to 402.1 MHz) and to measure the transmit symbol rate. The FM shall be accurate to 0.01 PPM (parts per million).

Digital Multi-Meter (DMM) - The DMM may be used for power supply voltage, RMS response to measure phase noise, and other measurements as deemed appropriate. NOTE : DCP phase noise may also be measured using the Demodulator programs.

RF Power Meter (RFPM) - The RFPM is used to measure the RF power amplifier output power. The response needs to be to RMS power. A Bird Wattmeter Model 43 with a 50-watt element with a ± 3 per cent accuracy at full range or approved equal is acceptable for these measurements.

Signal Generator (SG) - The SG is to be used for mixing the 402 MHz signal to the 5 MHz IF of the test demodulator. The SG phase noise shall be < 0.1 degree RMS. An HP 8660C or approved equal is acceptable for this testing.

Environmental Test Chamber (ETC) - The ETC is used to control the ambient test temperature of the DCP unit under test. A B40°C to 50°C range or greater is required.

General Purpose Oscilloscope - To measure and/or observe the relationship of AI@ and AQ@ data signals.

Laptop or IBM PC - To interface with the NOAA provided Demodulator Test Set.

Low Frequency Signal Controller/Modulator - An HP 33120A or equivalent. Used to generate modulation patterns and IF signals.

DCPRS Test Capabilities Required

During certification testing manufacturers must be able to disable or enable the DCP fail-safe circuitry as needed. Further a number of test sequences must be available on the unit to test various DCP functions. These include the following:

- | | |
|--------------------------------------|---|
| a) Carrier only | carrier phase noise, frequency |
| b) Clock pattern A0-1" | spectrum and clock pattern check, symbol rate |
| c) Repeating short message sequence | format checks |
| d) Longer message, repeating pattern | modulation and Inter-symbol Interference check, power measurement, spectrum |

The typical test set up is shown in Figure 1.

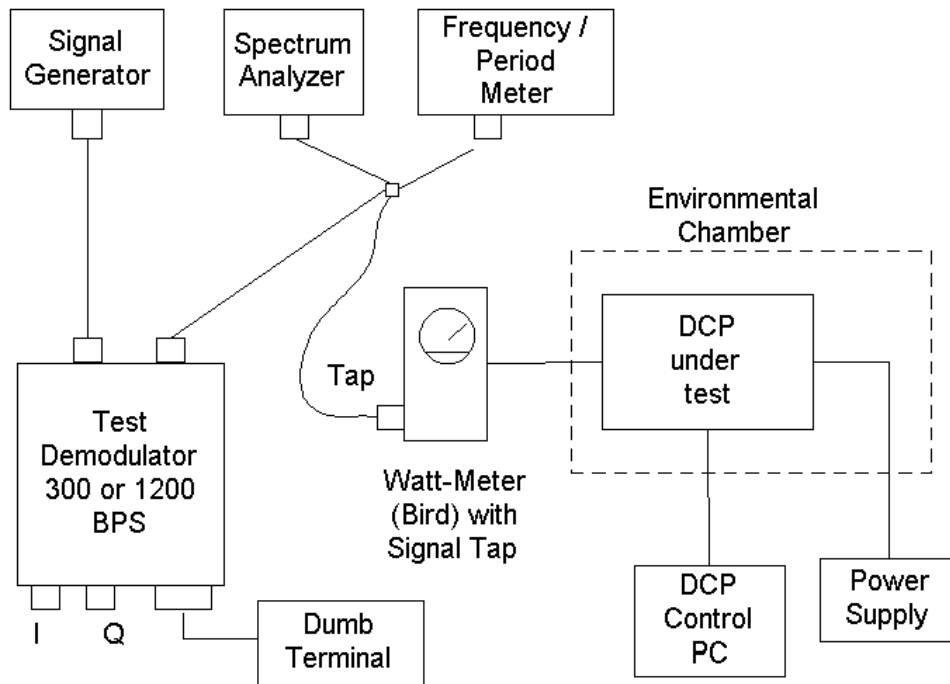

Fig. 1 TYPICAL DCP CERTIFICATION TEST SETUP

Some of the capabilities/features of the Test Demodulator are highlighted below:

Hardware Input

Input is direct from the manufacturer's DCP power amplifier. An internal wattmeter (50 watt load) with a coupler tap provides the low power level input required by the demodulator. A 0.01 PPM reference oscillator (with a single VCO loop) provides the LO and frequency measurement stability.

Unique Software Functions For the Test Set Demodulator

The demodulator makes signal quality measurements of all the signal variables of power, frequency, and phase. In the test case the measurements are required to be made in different sequences and accuracy. In the test case the noise floor is the base line phase noise of the system since the S/N typical of live signals is not applicable.

Power Measurement

Power is measured over a 27-dB range with an expected accuracy of +0.5 dB. The signal envelope inside of 180 Hz wide filter is measured for 300 bps and 800 Hz wide filter for 1200 bps. Power measurement can be made specifically at the carrier, clock, and 8 PSK modulation.

Frequency Measurement

The demodulator resolution is 1 Hz. The proposed LO has a 0.01-PPM stability. Accuracy of the measurement related to the reference and LO stability.

Phase Noise Measurement

Phase is measured with an eight bit Analog to Digital Converter. Resolution is 0.7 degree. Processing of many samples further improves resolution. Phase noise is measured during carrier only. Processing is over 1 second using 1000 samples with an expected accuracy of ± 0.2 degrees.

Modulation Measurement

A random set of symbols is sent by the test transmitter that has at least 1000 symbols. The phase is measured for each symbol and folded to 90-degree bins. The spread around the 45-degree nodes indicates any phase error. Phase spread is sent via the serial port to the demodulator terminal.

Symbol Rate

After carrier is sent clock symbols are sent continuously. There are two points of measurement for symbol rate on the front panel of the demodulator - the symbol strobe pulses and the "I" phase detector output. Time between pulses should indicate 150 or 600 symbol per second rate.

Message Format

The test transmitter sends a defined message to the test receiver, That same message should be repeated at the demodulator. This message will be sent for the three cases of the interleaver selections.

Carrier Length - Time between the detection of power level and first phase transition after phaselock.

Clock and MLS bits

Phase "1" or "0" sent to the output port. The exact transmission pattern is displayed.

Scrambling and Trellis Encoding

If the correct encoding is followed the data sent to the output port will be intelligible. An incorrect pattern will provide a meaningless data string. A test mode is provided to print out the measured symbol phase in terms of phase bin. The phase bins are numbered 0 to 71. This is the raw data prior to any processing.

EOT Detection - This should be visible in the test mode and from the demodulator recognition mask.

Test Demodulator Front End Filter

Attached is a copy of the receiver front end filter response curves for the 300 bps case. The 1200 bps front end filter is the same but centered at 8000 Hz with a four times the bandwidth. The key characteristics is a 3 dB bandwidth of 180 Hz and phase linear at 150 Hz to within 3 per cent of band edge. The response is shown in the below Figures.

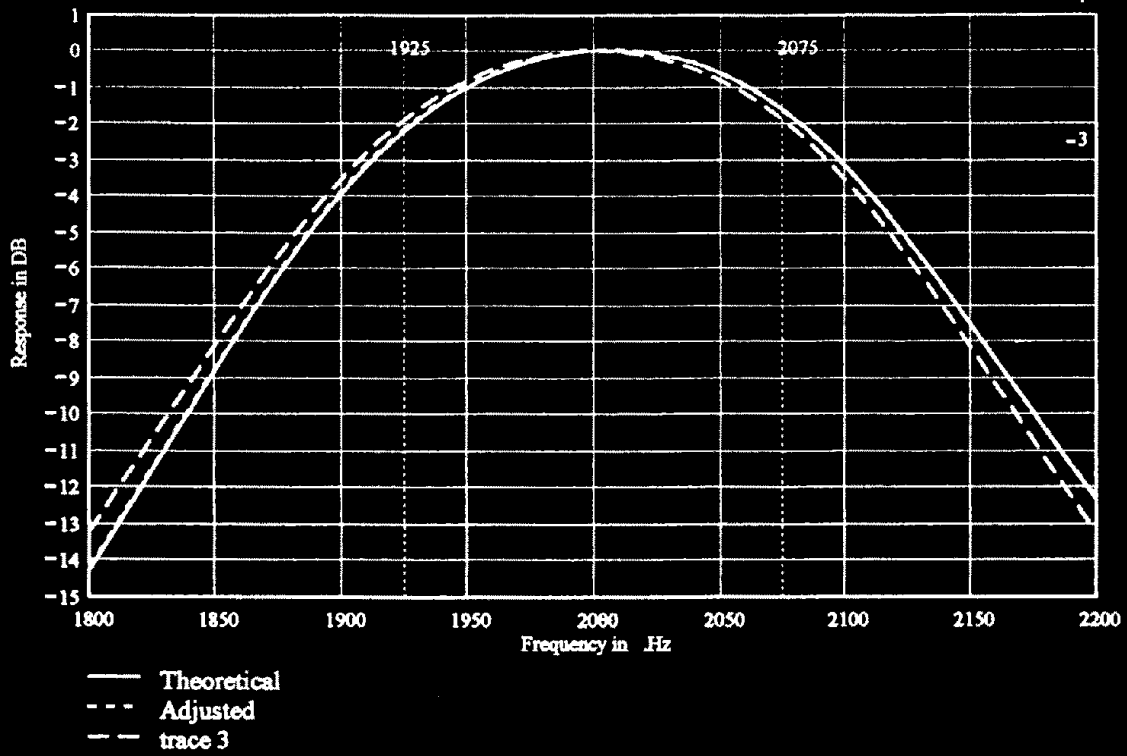

Full Response

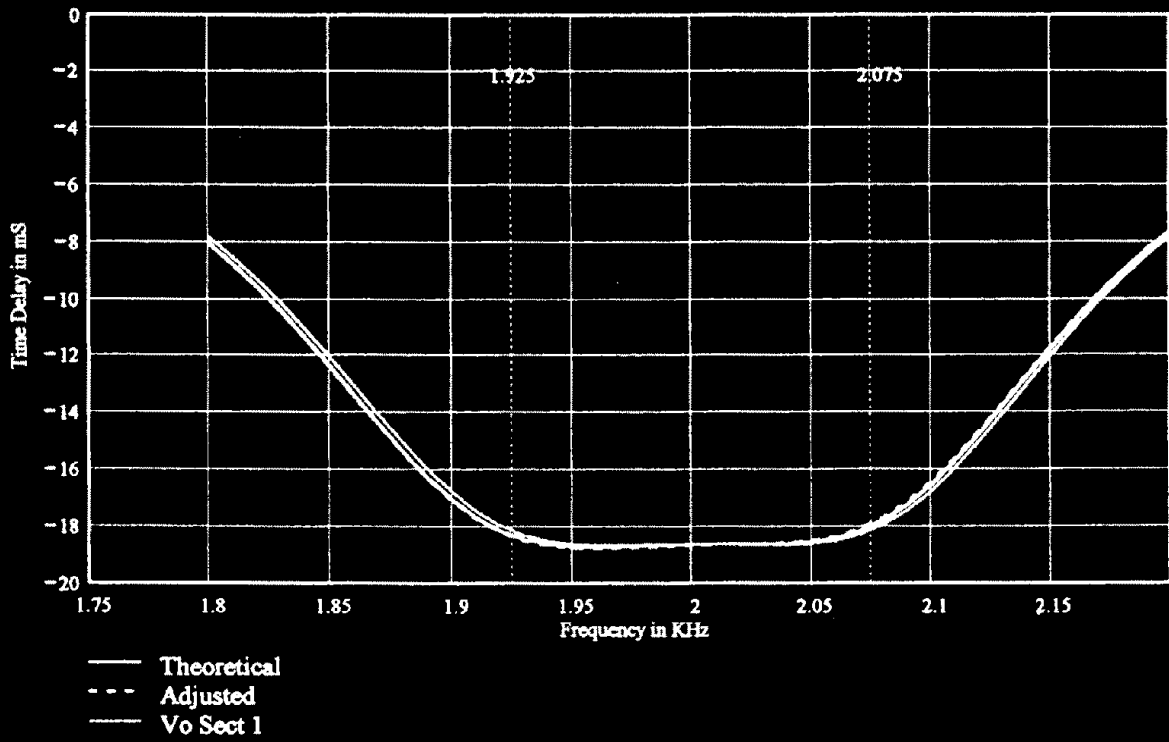

Time Delay Response

