

Coordination Group for Meteorological Satellites	LRIT/HRIT Global Specification	CGMS
		Doc. No. : CGMS 03 Issue : 2.6 Date : 9 July 1999

**Coordination Group for
Meteorological Satellites**

LRIT/HRIT Global Specification

CGMS Secretariat

EUMETSAT, Am Kavalleriesand 31, P.O.Box 100555, D-64205 Darmstadt, Germany

Tel: +49 6151 807 7 * Fax: +49 6151 807 555

Coordination Group for Meteorological Satellites	LRIT/HRIT Global Specification	CGMS
		Doc. No. : CGMS 03 Issue : 2.6 Date : 9 July 1999

DOCUMENT CHANGE RECORD

Issue	Date	DCN No.	Changed Pages/Paragraphs
2.3	5 July 1993		
2.4	21 April 1997		All section/figure renumbering and editorial changes sect. 5.4 introduction of data sequencing
2.5	5 October 1998		sect. 1.6.2 rearrangement of reference documents sect. 2.9 insertion of mission specific compression methods sect. 2.10 correction of service compatibility conform with [RD.5] sect. 4.2.2.7 insertion of key header record table sect. 4.3.2 correction of '<count>:=' syntax sect. 5.3 insertion of mission specific compression methods sect. 8.2.1 correction of M_PDU fill mechanism appendix C amendments in accordance with the above changes all minor editorial changes
<u>2.6</u>	<u>9 July 1999</u>		<u>sect. 4.3.3.3 correction of two formulae</u> <u>sect 7.1 correction of fig. 7-1</u>

Coordination Group for Meteorological Satellites	LRIT/HRIT Global Specification	CGMS
		Doc. No. : CGMS 03 Issue : 2.6 Date : 9 July 1999

TABLE OF CONTENTS

DOCUMENT CHANGE RECORD.....	I
TABLE OF CONTENTS.....	II
LIST OF FIGURES.....	V
LIST OF TABLES	VI
1. INTRODUCTION.....	1
1.1 PURPOSE OF THE MISSION.....	1
1.2 PURPOSE OF THIS DOCUMENT.....	1
1.3 SCOPE OF THIS DOCUMENT	1
1.4 CONVENTIONS.....	1
1.5 LRIT OR HRIT.....	2
1.6 REFERENCES	2
1.6.1 <i>Applicable Documents</i>	2
1.6.2 <i>Reference Documents</i>	2
2. SYSTEM OVERVIEW	3
2.1 COMMUNICATION MODEL.....	3
2.2 APPLICATION LAYER.....	4
2.3 PRESENTATION LAYER.....	5
2.4 SESSION LAYER.....	5
2.5 TRANSPORT LAYER.....	5
2.6 NETWORK LAYER.....	6
2.7 DATA LINK LAYER.....	6
2.8 PHYSICAL LAYER	6
2.9 APPLICABILITY OF STANDARDS.....	6
2.10 COMPATIBILITY WITH OTHER SERVICES.....	7
3. APPLICATION LAYER.....	8
4. PRESENTATION LAYER.....	9
4.1 GENERAL.....	9
4.2 LRIT/HRIT FILE STRUCTURE	9
4.2.1 <i>Top Level File Structure</i>	9
4.2.2 <i>Secondary Header Records</i>	12
4.2.2.1 Image Structure Record.....	12
4.2.2.2 Image Navigation Record.....	12
4.2.2.3 Image Data Function Record	13
4.2.2.4 Annotation Record	13
4.2.2.5 Time Stamp Record.....	13
4.2.2.6 Ancillary Text Record	14
4.2.2.7 Key Header Record	14
4.2.3 <i>Data Field Structure</i>	15
4.2.3.1 Image Data Files.....	15
4.2.3.2 GTS Message Files.....	16
4.2.3.3 Alphanumeric Text Files.....	16
4.2.3.4 Encryption Key Message File	16
4.3 INTERPRETATION OF IMAGE DATA.....	17
4.3.1 <i>Structure of Image Data</i>	17
4.3.2 <i>Explicit Image Data Definition</i>	18

Coordination Group for Meteorological Satellites	LRIT/HRIT Global Specification	CGMS
		Doc. No. : CGMS 03
		Issue : 2.6
		Date : 9 July 1999

4.3.3	<i>Default Image Data Definition</i>	19
4.4	NAVIGATION OF IMAGE DATA.....	20
4.4.1	<i>General</i>	20
4.4.2	<i>Outline of Navigation Functions</i>	20
4.4.3	<i>Projection Functions</i>	21
4.4.3.1	Geographical Coordinates.....	21
4.4.3.2	Normalized Geostationary Projection.....	22
4.4.3.3	Polarstereographic Projection	26
4.4.3.4	Mercator Projection.....	27
4.4.4	<i>Scaling Function</i>	28
5.	SESSION LAYER.....	29
5.1	GENERAL.....	29
5.2	ENCRYPTION	29
5.3	COMPRESSION	29
5.4	DATA SEQUENCING FUNCTION	30
5.5	TRANSMISSION SERVICE SPECIFICATION	30
5.5.1	<i>Syntax</i>	30
5.5.2	<i>Function</i>	30
5.6	RECEPTION SERVICE SPECIFICATION	31
5.6.1	<i>Syntax</i>	31
5.6.2	<i>Function</i>	31
6.	TRANSPORT LAYER.....	32
6.1	GENERAL.....	32
6.2	TRANSMISSION SERVICE SPECIFICATION	32
6.2.1	<i>Syntax</i>	32
6.2.2	<i>Function</i>	32
6.3	RECEPTION SERVICE SPECIFICATION	34
6.3.1	<i>Syntax</i>	34
6.3.2	<i>Function</i>	34
6.3.3	<i>Optional Functionality</i>	34
7.	NETWORK LAYER.....	35
7.1	GENERAL.....	35
7.2	TRANSMISSION SERVICE SPECIFICATION	37
7.2.1	<i>AOS Syntax</i>	37
7.2.2	<i>Function</i>	37
7.3	RECEPTION SERVICE SPECIFICATION	37
7.3.1	<i>AOS Syntax</i>	37
7.3.2	<i>Function</i>	37
8.	DATA LINK LAYER.....	38
8.1	OVERVIEW.....	38
8.2	VIRTUAL CHANNEL LINK CONTROL SUBLAYER.....	39
8.2.1	<i>General</i>	39
8.2.2	<i>Transmission Service Specification</i>	40
8.2.2.1	AOS Syntax	40
8.2.2.2	Function.....	40
8.2.3	<i>Reception Service Specification</i>	41
8.2.3.1	AOS Syntax	41
8.2.3.2	Function.....	41
8.3	VIRTUAL CHANNEL ACCESS SUBLAYER.....	42
8.3.1	<i>General</i>	42
8.3.2	<i>Transmission Service Specification</i>	43
8.3.2.1	AOS Syntax	43

Coordination Group for Meteorological Satellites	LRIT/HRIT Global Specification	CGMS
		Doc. No. : CGMS 03 Issue : 2.6 Date : 9 July 1999

8.3.2.2	Function	43
8.3.3	<i>Reception Service Specification</i>	46
8.3.3.1	AOS Syntax	46
8.3.3.2	Function	46
8.3.3.3	Optional Functionality.....	46
9.	PHYSICAL LAYER	48
	APPENDIX A - LIST OF ABBREVIATIONS	49
	APPENDIX B - DATA TYPES	51
	APPENDIX C - LIST OF MISSION SPECIFIC ITEMS	53

Coordination Group for Meteorological Satellites	LRIT/HRIT Global Specification	CGMS
		Doc. No. : CGMS 03 Issue : 2.6 Date : 9 July 1999

LIST OF FIGURES

FIGURE 2-1	COMMUNICATION MODEL	3
FIGURE 2-2	OVERALL DATA FLOW	4
FIGURE 4-1	LRIT/HRIT FILE STRUCTURE	11
FIGURE 4-2	GENERAL LRIT/HRIT HEADER RECORD STRUCTURE	11
FIGURE 4-3	LRIT/HRIT IMAGE STRUCTURE	15
FIGURE 4-4	EXAMPLE OF AN IMAGE CONTAINING SEVERAL SUBIMAGES	17
FIGURE 4-5	RELATIONSHIP BETWEEN GEOGRAPHICAL AND IMAGE COORDINATES	20
FIGURE 4-6	GEOGRAPHICAL COORDINATES	22
FIGURE 4-7	COORDINATE FRAMES FOR GEOS PROJECTION	23
FIGURE 4-8	NORMALIZED GEOSTATIONARY PROJECTION	25
FIGURE 4-9	POLARSTEREOGRAPHIC PROJECTION	26
FIGURE 4-10	MERCATOR PROJECTION	27
FIGURE 6-1	TRANSPORT FILE STRUCTURE	34
FIGURE 7-1	CP_PDU STRUCTURE	36
FIGURE 8-1	DATA LINK LAYER	38
FIGURE 8-2	M_PDU STRUCTURE	40
FIGURE 8-3	FILL PACKET	40
FIGURE 8-4	CVCDU STRUCTURE	42
FIGURE 8-5	VCDU PRIMARY HEADER	43
FIGURE 8-6	VCA TRANSMISSION SERVICE	45
FIGURE 8-7	VCA RECEPTION SERVICE	47
FIGURE B-1	CHARACTER CODE TABLE	52

Coordination Group for Meteorological Satellites	LRIT/HRIT Global Specification	CGMS
		Doc. No. : CGMS 03 Issue : 2.6 Date : 9 July 1999

LIST OF TABLES

TABLE 4-1	PRIMARY HEADER RECORD.....	9
TABLE 4-2	FILE TYPE.....	10
TABLE 4-3	HEADER RECORD TYPE	10
TABLE 4-4	IMAGE STRUCTURE RECORD	12
TABLE 4-5	IMAGE NAVIGATION RECORD	12
TABLE 4-6	IMAGE DATA FUNCTION RECORD.....	13
TABLE 4-7	ANNOTATION RECORD.....	13
TABLE 4-8	TIME STAMP RECORD	13
TABLE 4-9	ANCILLARY TEXT RECORD.....	14
TABLE 4-10	KEY HEADER RECORD.....	14

Coordination Group for Meteorological Satellites	LRIT/HRIT Global Specification	CGMS
		Doc. No. : CGMS 03 Issue : 2.6 Date : 9 July 1999

1. INTRODUCTION

1.1 Purpose of the Mission

The intention of LRIT/HRIT is to define a standard for dissemination of data, preferably from geostationary spacecraft towards LRIT/HRIT user stations.

The main approach of LRIT/HRIT is to disseminate rasterized image data mapped to the surface of the earth, preferably those generated by or deducted from satellite remote sensing data. Additionally, LRIT/HRIT shall provide means to forward other types of graphical information, alphanumeric data or binary data.

The (digital) LRIT mission shall replace the (analogue) WEFAX mission.

LRIT is intended for use on low rate communication links, mainly at 10 kbit/s until 256 kbit/s. HRIT is intended for use on high rate communication links, mainly at 0.256 Mbit/s through 10 Mbit/s.

1.2 Purpose of this Document

This document provides an architectural specification of the LRIT/HRIT mission from a telecommunications point of view. Thus it does neither define meteorological or other applications nor it specifies a user station for LRIT/HRIT.

While this document addresses global aspects only, mission specific aspects and implementation details are specified separately. Both this global specification and the mission specific addendum make up a complete definition of one LRIT/HRIT implementation.

1.3 Scope of this Document

Since the LRIT/HRIT dissemination mission is understood as a communication between "open systems", the architecture is conceptually similar to ISO standard 7498 (describing the OSI reference model). Network and data link layer are specified in conformance with the AOS recommendation, which is the cleanest and most modern adoption of the OSI model for space communications.

In section 2 an overview of the communication system is provided. Each layer of the communication model is specified in detail in the subsequent sections. Refer to appendix A for explanations of the acronyms used in this document.

1.4 Conventions

Within this document the terminology defined in ISO standard 7498 (OSI reference model) is used assuming the definitions given therein. As an extension, the terminology of CCSDS 701.0 (AOS architecture) is used for network and data link layers, without repeating the definitions and explanations given therein, too.

The CCSDS bit numbering convention is adopted for the entire specification herein. Be aware that bit streams are counted from the MSB onwards, beginning with 0. Groups of eight bits are denoted as "octets".

Coordination Group for Meteorological Satellites	LRIT/HRIT Global Specification	CGMS
		Doc. No. : CGMS 03 Issue : 2.6 Date : 9 July 1999

1.5 LRIT or HRIT

The mission shall be named LRIT (Low Rate Image Transmission) if the communication link provides a data rate below 256 kbit/s. If the data rate is greater than or equal 256 kbit/s then the mission shall be named HRIT (High Rate Image Transmission).

1.6 References

1.6.1 Applicable Documents

The subsequently listed documents form an integral part of this specification.

- [AD.1] CCSDS: "Advanced orbiting systems, networks and data links: architectural specification", CCSDS recommendation 701.0-B-2, November 1992
- [AD.2] ISO: "Information processing systems - open systems interconnection - basic reference model", ISO standard 7498-1, 1994
- [AD.3] ISO: "Information Technology - Digital Compression and Coding of Continuous-tone Still Images - Requirements and Guidelines, Compliance Testing and Extensions", ISO standards 10918-1, 10918-2, DIS 10918-3
- [AD.4] CCSDS: "Time code formats", CCSDS recommendation 301.0-B-2, April 1990
- [AD.5] CCSDS: "Telemetry channel coding", CCSDS recommendation 101.0-B-3, May 1992
- [AD.6] WMO: "Manual on the GTS", Publication No. 386, Geneva 1992

1.6.2 Reference Documents

The subsequently listed documents do not form an integral part of this specification. They are referenced to provide extended background information.

- [RD.1] CCSDS: "Advanced orbiting systems, networks and data links: summary of concept, rationale and performance", CCSDS report 700.0-G-3, November 1992
- [RD.2] not assigned
- [RD.3] CCSDS: "Radio frequency and modulation systems, part-1: earth stations and spacecraft", CCSDS recommendation 401.0-B, Issue 2, November 1994
- [RD.4] not assigned
- [RD.5] CGMS: CGMS 04 - "Direct Broadcast Services - LRPT/AHRPT Global Specification", Issue 1.0

Coordination Group for Meteorological Satellites	LRIT/HRIT Global Specification	CGMS
		Doc. No. : CGMS 03 Issue : 2.6 Date : 9 July 1999

2. SYSTEM OVERVIEW

2.1 Communication Model

In order to specify the LRIT/HRIT format ISO standard 7498 (OSI reference model) is used as a basis. LRIT/HRIT is mapped onto seven layers, conceptually similar to the OSI reference model. Figure 2-1 visualizes how the reference model is applied for LRIT/HRIT.

Due to the fact that LRIT/HRIT is a dissemination mission there is a unidirectional flow of information from a transmission system (denoted as TX) to a reception system (denoted as RX). In the physical representation the transmission system is the central LRIT/HRIT uplink station and the reception system is one LRIT/HRIT user station.

There are seven layers specified for the communication process, with increasing level of abstraction, beginning with the physical layer at the bottom of the stack, ending up with the application layer at its top. Below the communication system there is the communications media, which is the space path from the uplink station towards the user station including the transponder functionality of the spacecraft.

For each of the communications layers a service data unit (SDU) can be defined, which is the data structure appearing at the top of that layer. Additionally, for each layer there is a set of services to be named. In this special application, the TX services for one layer receive the related SDU as input, and the RX services generate the related SDU as output.

LRIT/HRIT provides means for packetized communication. Several application processes on the TX side may send data, virtually parallel, to their partners on the RX side. Each application process is identified by its application process identifier (APID). Figure 2-2 shows the situation. For LRIT/HRIT, layers 1...6 are specified.

In the subsequent sections (2.2 - 2.8) there is an outline of the communication layers. In sections 3 through 9 each communication layer is specified in detail then.

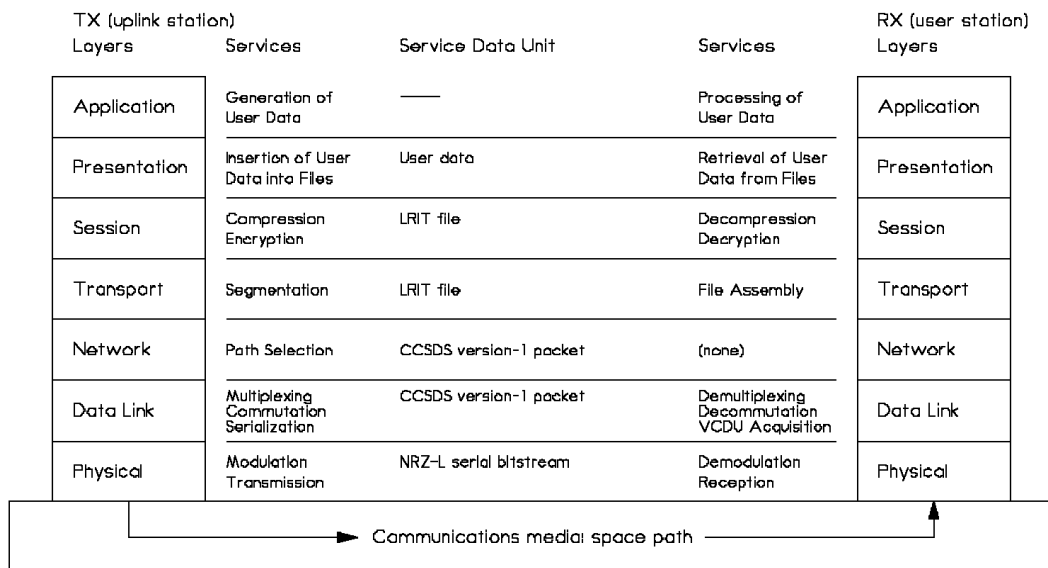

Figure 2-1 Communication Model

Coordination Group for Meteorological Satellites	LRIT/HRIT Global Specification	CGMS
		Doc. No. : CGMS 03 Issue : 2.6 Date : 9 July 1999

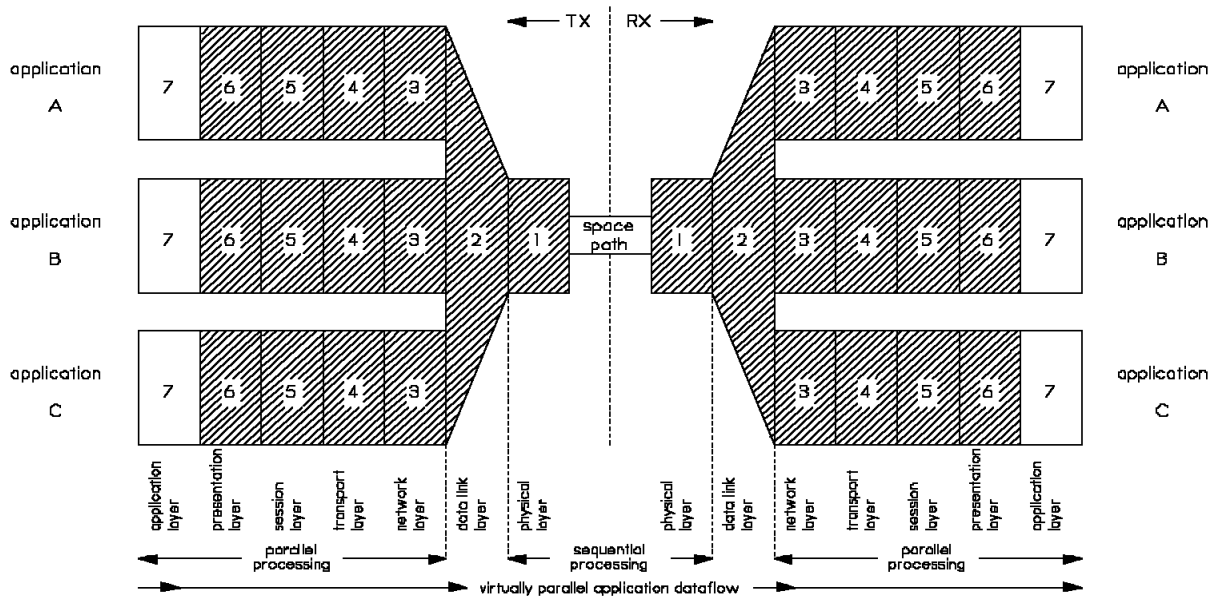

Figure 2-2 Overall Data Flow

2.2 Application Layer

The application layer describes the information interchange between application entities.

Examples for application entities on the TX side could be

- a process generating image products from remote sensing data
- a spacecraft operator issuing an administrative message
- a process generating meteorological bulletins.

On the RX side one could find possible application entities in

- a process visualizing image loops
- a user station operator reading an administrative message
- an application program processing meteorological bulletins.

There is no service data unit for the application layer.

Coordination Group for Meteorological Satellites	LRIT/HRIT Global Specification	CGMS
		Doc. No. : CGMS 03 Issue : 2.6 Date : 9 July 1999

2.3 Presentation Layer

The service data unit for the presentation layer is the user data (e.g. image product, administrative message, meteorological bulletin), which it is receiving from or sending to the application layer. Within the presentation layer the information is transformed from a form suitable for presentation (i.e. user data) to a form suitable for issuing a communications session (i.e. a file containing LRIT/HRIT data) or vice versa.

Consequently, from the presentation layer point of view, the underlying communication is a transfer of LRIT/HRIT files from the transmission system to the reception system, each of them represented by its session layer.

Within the presentation layer the detailed structure of LRIT/HRIT files is specified, but neither the possible usage of the data therein (this belongs to the application layer) nor the method of sending it from the TX presentation layer towards the RX presentation layer (this belongs to the session layer).

2.4 Session Layer

The session layer describes how an LRIT/HRIT file (the session SDU) is sent from the TX system to the RX system, without uncovering the transport mechanism. For LRIT/HRIT dissemination, there are two pairs of complementary services to be performed:

- compression and decompression of data, if required
- encryption and decryption of data, if required

In addition a mission specific data sequencing on 'LRIT/HRIT file level' could be applied as an alternative to the priority scheme used in the transport layer to cope with stringent data specific timeliness requirements.

From the session layer point of view, the underlying communication can be described as the transportation of an LRIT/HRIT file (prepared for shipping) from TX transport layer to RX transport layer.

2.5 Transport Layer

The transport layer provides means for transferring a file through the packet multiplexing network.

On the TX side a suitable packet channel is selected and the file is partitioned into one or more segments, each of them packed into a CCSDS conforming source data packet.

On the RX side the file segments are retrieved from incoming packets and the segments are reassembled to LRIT/HRIT files.

Thus, the transport layer does not know anything about structure and contents of the LRIT/HRIT files it is transporting nor it is involved in how source packets are forwarded from the TX system to the RX system.

Coordination Group for Meteorological Satellites	LRIT/HRIT Global Specification	CGMS
		Doc. No. : CGMS 03 Issue : 2.6 Date : 9 July 1999

2.6 Network Layer

The network layer is responsible for controlling the path on which a source is transferred through the communication system. For LRIT/HRIT, the only activity required is to select the path (i.e. the virtual channel) upon transmitting a source packet, and to forward it to the transport layer of its addressed application upon reception.

2.7 Data Link Layer

The data link layer performs the transfer of a CCSDS source packet on a predefined path through the data link.

The underlying communication system is capable of forwarding a serial bitstream from the transmission system to the reception system, both represented by its physical layers.

While multiple communication tasks may run on the higher layers simultaneously, the underlying physical layer is capable of transferring a single bitstream only. Consequently, incoming source packets must be multiplexed on the transmitting side and demultiplexed on the receiving side. Below packet multiplexing, the virtual channel data units (VCDUs) must be commutated onto the physical link and decommutated at the receiving side. Last, the VCDU stream must be serialized on the TX side and the VCDUs must be acquired from the serial bitstream on the RX side.

2.8 Physical Layer

The physical layer performs the transfer of the serial bitstream from the TX system to the RX systems. For this purpose, the bitstream must be modulated onto a transmission carrier signal and demodulated on the receiving side. The modulated signal must be transmitted through the communications media and received from that on the receiving side.

2.9 Applicability of Standards

LRIT/HRIT should be understood as an open system by design, conceptually similar to OSI reference model defined in ISO 7498 [AD.2].

Network layer and data link layer are specified according to CCSDS recommendation 701 for advanced orbiting systems [AD.1].

Related to that, the applied FEC mechanism (on data link layer) conforms with CCSDS recommendation 101 [AD.5]. The use of FEC (e.g. convolutional coding) in the physical layer and its concatenation with the data link layer FEC (Reed-Solomon coding) is **mission specific**.

As far as time codes are used in the data structures, they are defined in accordance with CCSDS recommendation 301 [AD.4].

Compression of image data is either performed in accordance with the "JPEG" standard [AD.3] or in accordance with any other compression algorithm identified via a **mission specific** header.

Coordination Group for Meteorological Satellites	LRIT/HRIT Global Specification	CGMS
		Doc. No. : CGMS 03 Issue : 2.6 Date : 9 July 1999

2.10 Compatibility with Other Services

It is intended to specify LRIT as compatible as possible with LRPT [RD.5], which is the related "secondary" dissemination service from polar orbiting satellites. For this reason, the data link and network layers of both protocols are compatible as far as it concerns the RX side.

Coordination Group for Meteorological Satellites	LRIT/HRIT Global Specification	CGMS
		Doc. No. : CGMS 03 Issue : 2.6 Date : 9 July 1999

3. APPLICATION LAYER

The application layer is the window between the application process and the communication system. For LRIT/HRIT we have to outline possible applications of the data forwarded through the communication system.

There are no global specifications related to the application layer.

Coordination Group for Meteorological Satellites	LRIT/HRIT Global Specification	CGMS
		Doc. No. : CGMS 03 Issue : 2.6 Date : 9 July 1999

4. PRESENTATION LAYER

4.1 General

The presentation layer provides means for representation of information. The structure of data sets is defined herein together with all codes used therein. For image data services are provided for navigation and for retrieving their physical interpretation.

The presentation layer is completely defined by specifying syntax and semantics of LRIT/HRIT files. Section 4.2 provides a general definition, while section 4.3 (interpretation of image data) and section 4.4 (navigation of image data) address complex aspects related to image files only.

4.2 LRIT/HRIT File Structure

4.2.1 Top Level File Structure

An LRIT/HRIT file consists of one or more header records and one data field (see Figure 4-1).

In the header records information describing the contents of the data field is provided.

Each header record has the structure outlined in Figure 4-2. Up to 256 types of header records can be defined. Some of them may occur several times with one file. The first header record (which is the only one being mandatory) must be of type 0 identifying it as the so-called primary header record.

The structure of the **primary header record** is as follows:

size in octets	data type	contents
1	integer, unsigned	header type, set to 0
2	integer, unsigned	header record length, set to 16
1	integer, unsigned	file type code, determining the top level structure of the file data field
4	integer, unsigned	total header length, specifying the total size of all header records (including this one) in octets
8	integer, unsigned	data field length, specifying the total size of the file data field in bits.

Table 4-1 Primary Header Record

Coordination Group for Meteorological Satellites	LRIT/HRIT Global Specification	CGMS
		Doc. No. : CGMS 03 Issue : 2.6 Date : 9 July 1999

The following **file types** are supported:

code	file type
0	image data file
1	GTS message
2	alphanumeric text file
3	encryption key message
4...127	reserved for future global usage
128...255	for mission specific use

Table 4-2 File Type

The following **header record types** are supported:

code	header record type	mandatory for file type	optional for file type
0	primary header	all	-
1	image structure	0	-
2	image navigation	-	0
3	image data function	-	0
4	annotation	-	all
5	time stamp	-	all
6	ancillary text	-	all
7	key header	-	all
8...127	reserved for future global usage		
128...255	for mission specific use		

Table 4-3 Header Record Type

Coordination Group for Meteorological Satellites	LRIT/HRIT Global Specification	CGMS
		Doc. No. : CGMS 03 Issue : 2.6 Date : 9 July 1999

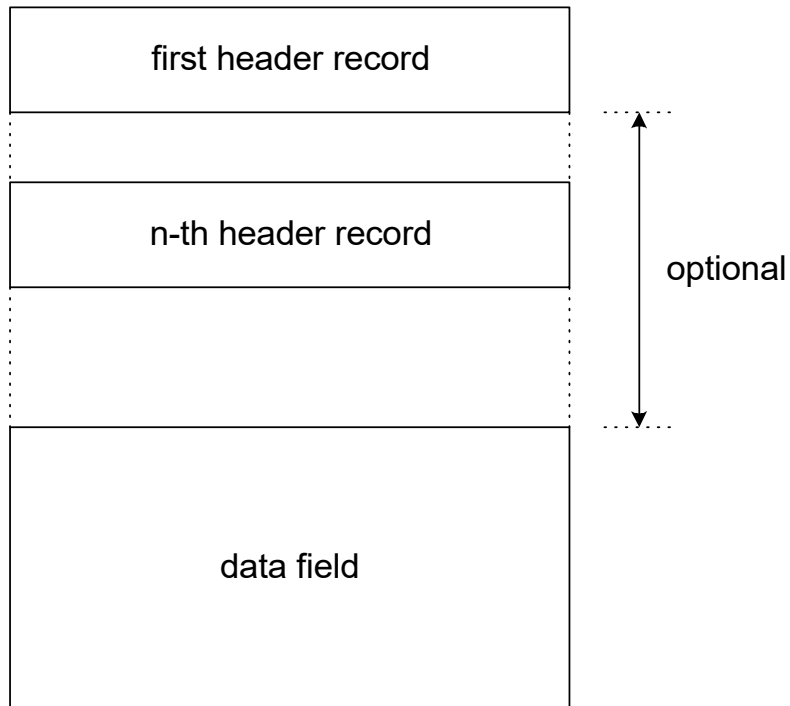

Figure 4-1 LRIT/HRIT File Structure

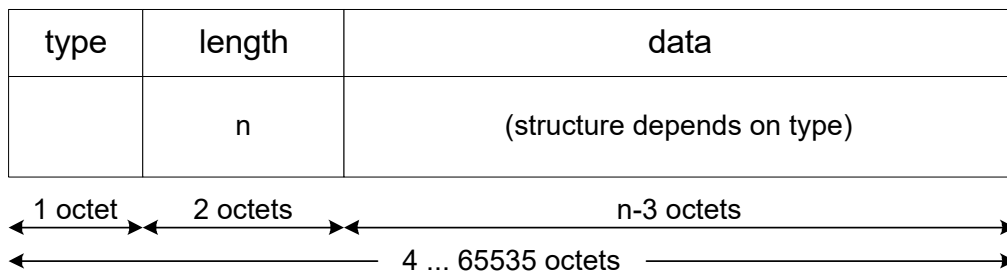

Figure 4-2 General LRIT/HRIT Header Record Structure

Coordination Group for Meteorological Satellites	LRIT/HRIT Global Specification	CGMS
		Doc. No. : CGMS 03 Issue : 2.6 Date : 9 July 1999

4.2.2 Secondary Header Records

4.2.2.1 Image Structure Record

This record determines the structure of an image. It is mandatory for image data files and applicable to image data files only. The structure is as follows:

size in octets	data type	contents	abbreviation
1	integer, unsigned	header type, set to 1	
2	integer, unsigned	header record length, set to 9	
1	integer, unsigned	number of bits per pixel (1 ... 255)	NB
2	integer, unsigned	number of columns (1 ... 65535)	NC
2	integer, unsigned	number of lines (1 ... 65535)	NL
1	integer, unsigned	compression flag (0,1,2)	CFLG

Table 4-4 Image Structure Record

Refer to section 4.2.3.1 for details on image data.

4.2.2.2 Image Navigation Record

This record determines the mapping of the image onto the earth. It is applicable to image data files only. The structure is as follows:

size in octets	data type	contents	abbreviation
1	integer, unsigned	header type, set to 2	
2	integer, unsigned	header record length, set to 51	
32	character	projection name	
4	integer, signed	column scaling factor	CFAC
4	integer, signed	line scaling factor	LFAC
4	integer, signed	column offset	COFF
4	integer, signed	line offset	LOFF

Table 4-5 Image Navigation Record

Refer to section 4.4 for details on image navigation.

Coordination Group for Meteorological Satellites	LRIT/HRIT Global Specification	CGMS
		Doc. No. : CGMS 03 Issue : 2.6 Date : 9 July 1999

4.2.2.3 Image Data Function Record

This record determines the physical meaning of the image data. The structure is as follows:

size in octets	data type	contents
1	integer, unsigned	header type, set to 3
2	integer, unsigned	header record length
up to 65532	character	data definition block

Table 4-6 Image Data Function Record

Refer to section 4.3.2 for details about the data definition block.

4.2.2.4 Annotation Record

This record is used to specify an alphanumeric annotation for the file. It is optional for all file types. The structure is as follows:

size in octets	data type	contents
1	integer, unsigned	header type, set to 4
2	integer, unsigned	header record length
up to 64	character	annotation text

Table 4-7 Annotation Record

4.2.2.5 Time Stamp Record

This record is used to apply a time stamp to the file. It is optional for all file types. The structure is as follows:

size in octets	data type	contents
1	integer, unsigned	header type, set to 5
2	integer, unsigned	header record length, set to 10
7	CCSDS time	time stamp

Table 4-8 Time Stamp Record

Coordination Group for Meteorological Satellites	LRIT/HRIT Global Specification	CGMS
		Doc. No. : CGMS 03 Issue : 2.6 Date : 9 July 1999

4.2.2.6 Ancillary Text Record

This record is used to attach ancillary text information to the file. It is optional for all file types. The structure is as follows:

size in octets	data type	contents
1	integer, unsigned	header type, set to 6
2	integer, unsigned	header record length
up to 65532	character	ancillary text

Table 4-9 Ancillary Text Record

4.2.2.7 Key Header Record

This record is used to control encryption of the file. It has no meaning within the presentation layer. Any such header record, identified by header type 7, shall be ignored by the presentation layer.

size in octets	data type	contents
1	integer, unsigned	header type, set to 7
2	integer, unsigned	header record length
up to 65532	character	key header information (mission specific)

Table 4-10 Key Header Record

Coordination Group for Meteorological Satellites	LRIT/HRIT Global Specification	CGMS
		Doc. No. : CGMS 03 Issue : 2.6 Date : 9 July 1999

4.2.3 Data Field Structure

4.2.3.1 Image Data Files

The data field of image data files consists of a sequence of pixels, without any gaps inbetween. The size of one pixel (in bits) is specified in the image structure record (sect. 4.2.2.1) as well as the number of columns (denoted as NC in the following) and the number of lines (NL herein). The pixels appear with the MSB first. The total number of pixels is $NC \cdot NL$, thus the total data field size is $NC \cdot NL$ times the pixel size. The pixels are sorted linewise, from left to right and from top to bottom. Accordingly, column numbers are counted from 1 to NC, and line numbers from 1 to NL. Consequently, the first pixel in the data field (the left uppermost one) has the coordinates (1,1) and the last pixel (the bottom right one) has the coordinates (NC, NL). Figure 4-3 shows the structure of an LRIT/HRIT image.

The compression flag in the image structure record has no direct effect on the presentation of image data, however the following shall be noted:

- The usage of compression (CFLG = 1 or 2) may cause restriction on the permitted values for NB.
- If a **lossy compression method** is used (CFLG = 2), users shall be aware of the nonperfect reconstruction of data. From the users point of view there is no difference whether transmission is performed **without compression** (CFLG = 0) or with **lossless compression** (CFLG = 1).

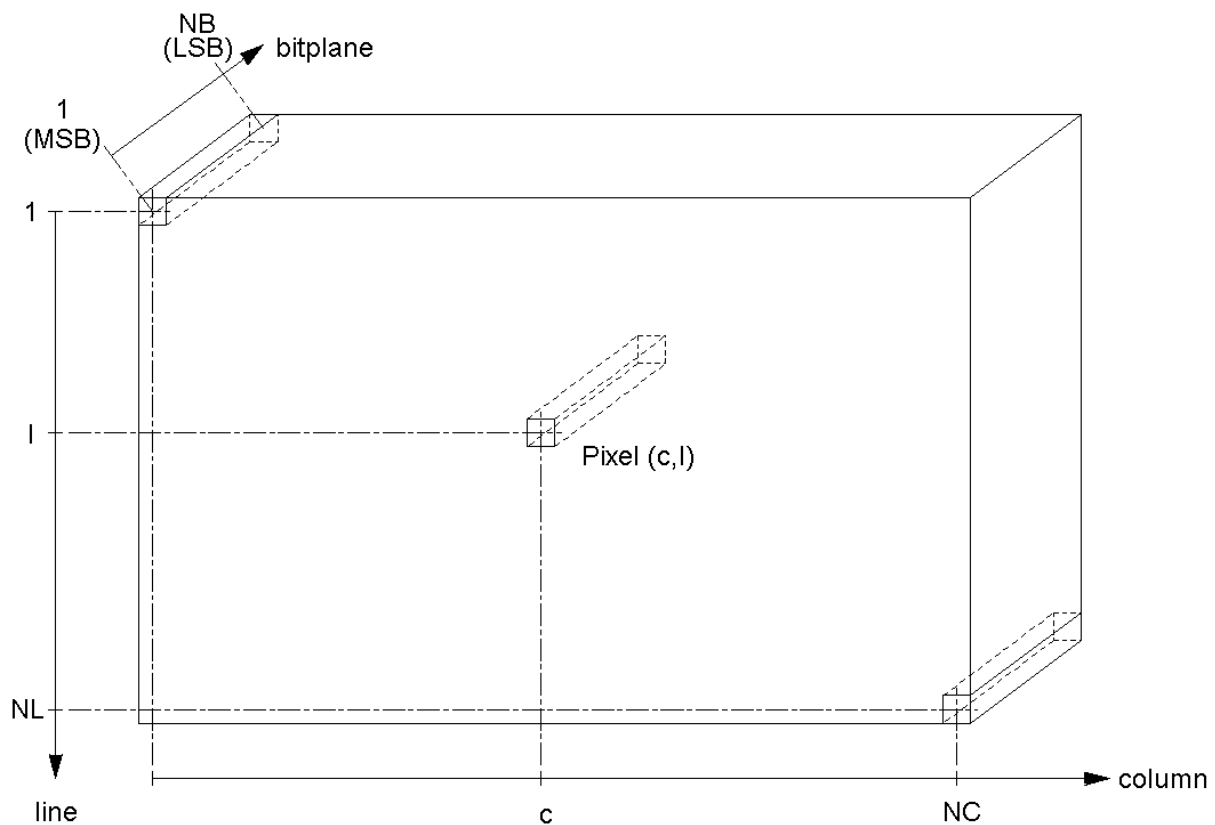

Figure 4-3 LRIT/HRIT Image Structure

Coordination Group for Meteorological Satellites	LRIT/HRIT Global Specification	CGMS
		Doc. No. : CGMS 03 Issue : 2.6 Date : 9 July 1999

4.2.3.2 GTS Message Files

The data field of a bulletin file consists of one meteorological message as specified in [AD.6].

A meteorological message used for LRIT/HRIT has the following structure:

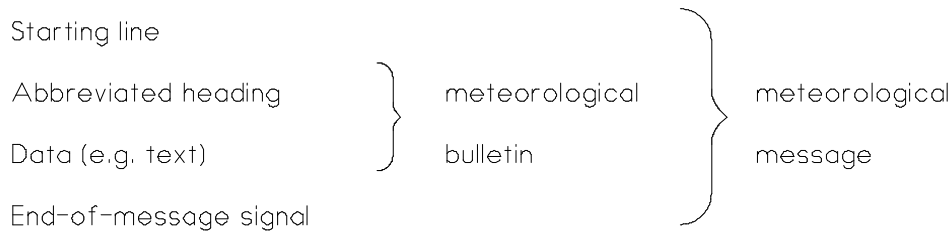

Except for the data, international alphabet no. 5 must be used for all elements of the message (refer to appendix B). The starting line looks as follows:

<SOH> <CR> <CR> <LF> nnn [<SP> CLLLL]

with nnn denoting the transmission sequence number and CLLLL denoting classification and identification group.

Note: According to a WMO recommendation the use of CLLLL is not mandatory any longer and can be discontinued.

The abbreviated heading has the following structure:

<CR> <CR> <LF> TTAAii <SP> CCCC <SP> YYGGgg [<SP> BBB]

with TTAAii denoting the data designators, CCCC being the station indicator and YYGGgg containing the international date-time group. The optional BBB indicator is used to avoid multiply occurring abbreviated headings.

The end-of-message signal is defined as follows:

<CR> <CR> <LF> <ETX>

For details on meteorological messages the reader shall refer to [AD.6].

4.2.3.3 Alphanumeric Text Files

The data field consists of a sequence of ASCII coded characters, using one octet per character. Consecutive lines of text shall be separated by <CR><LF>. Refer to appendix B for definition of the code.

4.2.3.4 Encryption Key Message File

These files are used for distribution of key information within an encryption infrastructure. The data field structure is **mission specific**.

Coordination Group for Meteorological Satellites	LRIT/HRIT Global Specification	CGMS
		Doc. No. : CGMS 03 Issue : 2.6 Date : 9 July 1999

4.3 Interpretation of Image Data

4.3.1 Structure of Image Data

One image consists of a matrix of pixels, each of them having the same structure. The matrix size is defined by NC and NL in the image structure record (refer to section 4.2.2.1), the size of one pixel is defined by NB.

The bits of one pixel are oriented from MSB through LSB, counted from 1 to NB. The matrix made up by selecting one specific bit from every pixel is called bitplane. One image consists of NB bitplanes.

One image consists of one or more subimages, each of them made up by a group of one or more consecutive bitplanes. One subimage refers to one set of information (e.g. radiometer channel, graphic overlay etc.). Figure 4-4 shows a configuration of several subimages.

In analogy, one pixel consists of one or more subpixels. The default value of one subpixel is determined by the binary representation of its bits (called subpixel count), thus inbetween 0 and 2^n-1 (where n denotes the number of bitplanes belonging to the subimage). Other values may be assigned to a subpixel by means of suitable equivalence statements in the data definition block contained in the (optional) image data function record (refer to section 4.2.2.3).

Note that all subimages are transmitted in parallel. Refer to section 4.2.3.1 on how the image data is presented.

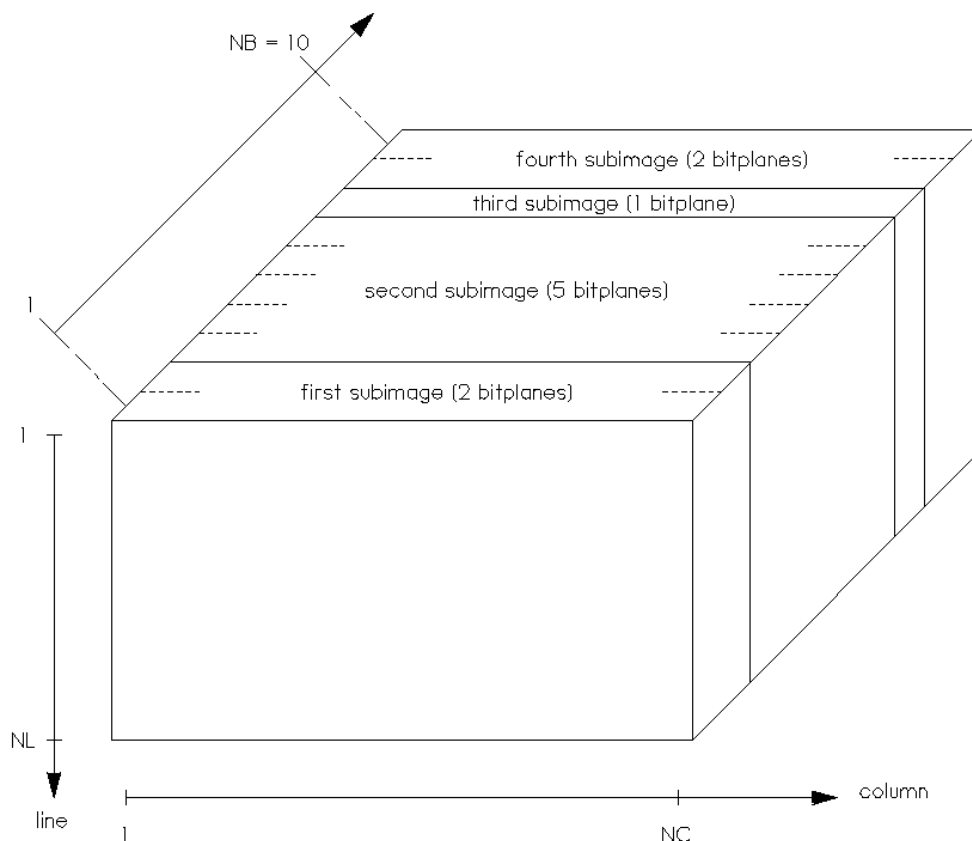

Figure 4-4 Example of an Image containing several Subimages

Coordination Group for Meteorological Satellites	LRIT/HRIT Global Specification	CGMS
		Doc. No. : CGMS 03 Issue : 2.6 Date : 9 July 1999

4.3.2 Explicit Image Data Definition

In order to specify the data of one image file, a data definition block may be submitted with an (optional) image data function record (refer to section 4.2.2.3).

The data definition block consists of one or more statements, separated by the delimiter <CR>. Within the statement, zero or more <SP>, <HT>, <LF> characters may be inserted anywhere.

The meaning of one subimage can be defined with one type statement:

<type> := <number of bitplanes>

All bitplanes must be defined, the first type statement defines the most significant bit(s), the last statement defines the least significant bit(s). The following values are supported for <type>:

\$HALFTONE

Specifies a halftone greyscale, i.e. the subpixel counts are related to quantized samples of a continuous physical value (such as "intensity" or "temperature").

\$DISCRETE

Specifies a discrete greyscale, i.e. each subpixel count has a unique meaning (such as "snow", "rain", "water", "land", or "cloud").

\$OVERLAY

Specifies a discrete overlay. All zero represents the overlay to be off. All other subpixel counts represent overlay conditions.

The variable <number of bitplanes> may be set to any decimal integer between 1 and NB (refer to section 4.2.2.1). Not more than 3 digits must be provided. The sum of all <number of bitplanes> in all type statements must be equal to the number of bits per pixel (i.e. NB). The value 1 is not permitted for \$HALFTONE.

After each type statement zero or more non-type statements may appear, providing more definitions related to the subimage specified by the preceding type statement. The following statements are supported:

_NAME:=<name>

Specifies a name for the subimage, such as "Infrared" or "Normalized Vegetation Index" or "Cloud classification". <name> denotes a character string not longer than 64 characters. The usage of this statement is optional for all types. It must not occur more than once with one type statement.

_UNIT:=<unit>

Specifies a physical unit to be used with the subimage such as "Degree Celsius". This statement is supported for \$HALFTONE and \$DISCRETE types only. It is optional. It must not occur more than once with one type statement.

<count>:=<numeric value>

establishes a relationship between a numeric value and one subpixel count. The variable <count> may be set to any decimal integer between 0 and $2^n - 1$ where n represents the number of bitplanes in the preceding type statement. The numeric value can be any integer or real, consisting of a "+" or "-" sign, decimal digits and a decimal point. Sign and decimal point have to be specified if needed only. The entire string describing the numeric value must not exceed 64 characters in

Coordination Group for Meteorological Satellites	LRIT/HRIT Global Specification	CGMS
		Doc. No. : CGMS 03 Issue : 2.6 Date : 9 July 1999

length. The usage of this statement is optional for all types. Equivalencing a subset of all possible counts is permitted. In case of \$HALFTONE type, linear interpolation is assumed for bridging definition gaps.

<count>:=<alphanumeric value>

establishes a relationship between an alphanumeric meaning and a subpixel count. The variable may be set to any decimal integer between 0 and 2^n-1 where n represents the number of bitplanes in the preceding type statement. The alphanumeric value can be any character string not longer than 64 characters. The usage of this statement is optional for all types.

Note that each <count> value can only be used once for one subimage data definition.

4.3.3 Default Image Data Definition

If no image data function record is provided with the image file then the following is assumed: The image consists of one subimage. The data function type is \$HALFTONE, except for NB=1 where \$DISCRETE is assumed. No data name, no unit name and no value equivalences are specified.

Coordination Group for Meteorological Satellites	LRIT/HRIT Global Specification	CGMS
		Doc. No. : CGMS 03 Issue : 2.6 Date : 9 July 1999

4.4 Navigation of Image Data

4.4.1 General

Each pixel of an LRIT/HRIT image is addressed by a pair of coordinates: the column number c and the line number l . Refer to Figure 4-3 for details.

Optionally, by means of an image navigation record (refer to section 4.2.2.2), the line-column raster can be mapped to geographical coordinates and vice versa.

In the following this relation is defined.

4.4.2 Outline of Navigation Functions

The relation between image coordinates and geographical coordinates is determined by the concatenation of two functions in each direction:

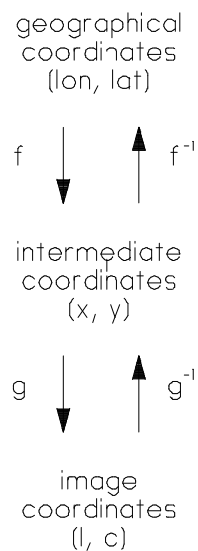

Figure 4-5 Relationship between geographical and image coordinates

Note that the geographical coordinates (lon and lat) and the intermediate coordinates (x and y) are real numbers while the image coordinates (l and c) are integer numbers.

Coordination Group for Meteorological Satellites	LRIT/HRIT Global Specification	CGMS
		Doc. No. : CGMS 03 Issue : 2.6 Date : 9 July 1999

The projection functions

$$\begin{pmatrix} x \\ y \end{pmatrix} = f \begin{pmatrix} lon \\ lat \end{pmatrix} \quad \text{and} \quad \begin{pmatrix} lon \\ lat \end{pmatrix} = f^{-1} \begin{pmatrix} x \\ y \end{pmatrix}$$

are nonlinear functions specified by the projection name. Refer to section 4.4.3 for details on global definitions. More projection functions may be specified for the actual implementation (i.e. mission specific).

The scaling functions

$$\begin{pmatrix} c \\ l \end{pmatrix} = g \begin{pmatrix} x \\ y \end{pmatrix} \quad \text{and} \quad \begin{pmatrix} x \\ y \end{pmatrix} = g^{-1} \begin{pmatrix} c \\ l \end{pmatrix}$$

are linear functions specified by the scaling factors CFAC and LFAC and by the offsets COFF and LOFF. Refer to section 4.4.4 for details.

4.4.3 Projection Functions

4.4.3.1 Geographical Coordinates

For LRIT/HRIT, one location on earth is determined by its longitude (lon) and its geographical latitude (lat). Both coordinates are specified in degree.

The longitude is counted eastwards positive, beginning at the Greenwich meridian. The permitted range is -180.0 ... +180.0. The latitude is counted from -90.0 (south pole) through 0.0 (equator) until +90.0 (north pole).

Figure 4-6 shows the situation for a spherical model of the earth. Note that when using an ellipsoid as a model of the earth, geographical and geocentric latitude will be different.

Coordination Group for Meteorological Satellites	LRIT/HRIT Global Specification	CGMS
		Doc. No. : CGMS 03 Issue : 2.6 Date : 9 July 1999

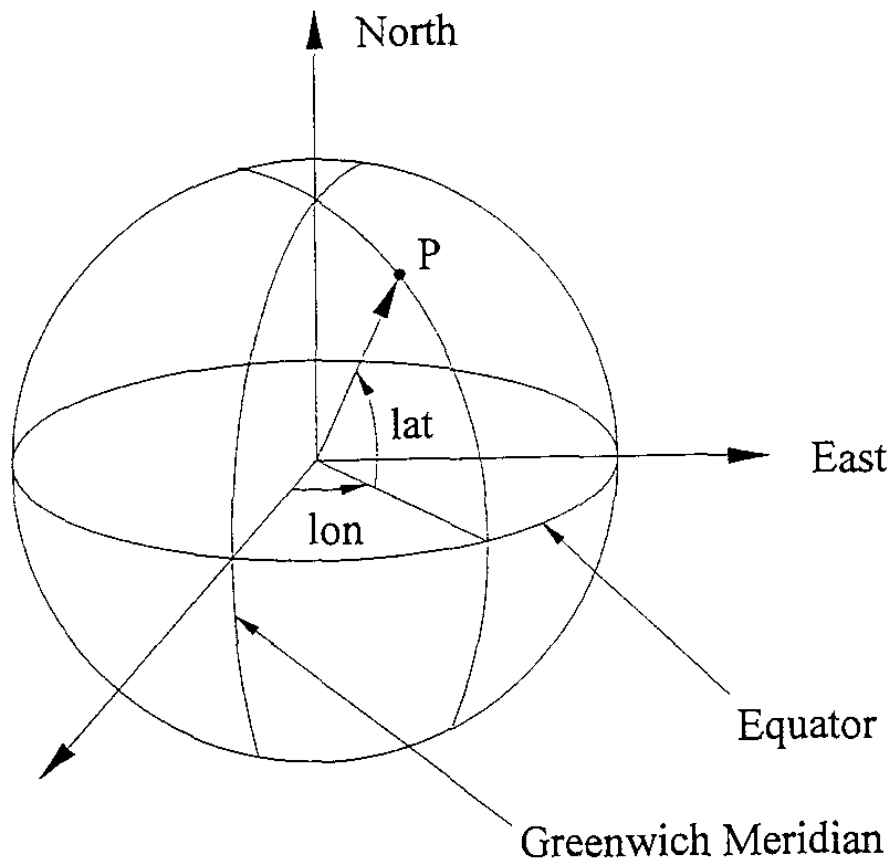

Figure 4-6 Geographical Coordinates

4.4.3.2 Normalized Geostationary Projection

The projection name string shall be specified as

GEOS (<sub_lon>)

where <sub_lon> specifies the subsatellite longitude in degree, as an integer or real decimal string.

The normalized geostationary projection describes the view from a virtual satellite to an idealized earth. Herein, the virtual satellite is in a geostationary orbit, perfectly located in the equator plane exactly at longitude sub_lon. The distance between spacecraft and centre of earth is 42164 km. The idealized earth is a perfect ellipsoid with an equator radius of 6378.1690 km and a polar radius of 6356.5838 km.

In the following a short description of the theoretical background is provided:

Two cartesian coordinate frames are introduced. (e_1, e_2, e_3) has its origin in the centre of the earth. (e_3) points in northern direction, (e_1) points towards the Greenwich meridian. (s_1, s_2, s_3) has its origin at the satellite position. Again (s_3) points northwards, and (s_1) directs to the centre of the earth. Figure 4-7 visualizes this situation and identifies several angles and lengths used in the following.

The earth is described as an oblate rotational ellipsoid.

Coordination Group for Meteorological Satellites	LRIT/HRIT Global Specification	CGMS
		Doc. No. : CGMS 03 Issue : 2.6 Date : 9 July 1999

$$\frac{e_3^2}{r_{pol}^2} + \frac{e_1^2 + e_2^2}{r_{eq}^2} = 1$$

$$r_{pol} = 6356.5838 \text{ km}$$

$$r_{eq} = 6378.1690 \text{ km}$$

The vector r_e points from the centre of the earth to a point P on the earth's surface. Thus, λ_e is the longitude and ϕ_e is the geocentric latitude describing the point P. The transformation from geographic coordinates (lon, lat) is as follows:

$$\lambda_e = lon$$

$$\phi_e = \arctan \left[\left(\frac{r_{pol}^2}{r_{eq}^2} \right) \cdot \tan(lat) \right]$$

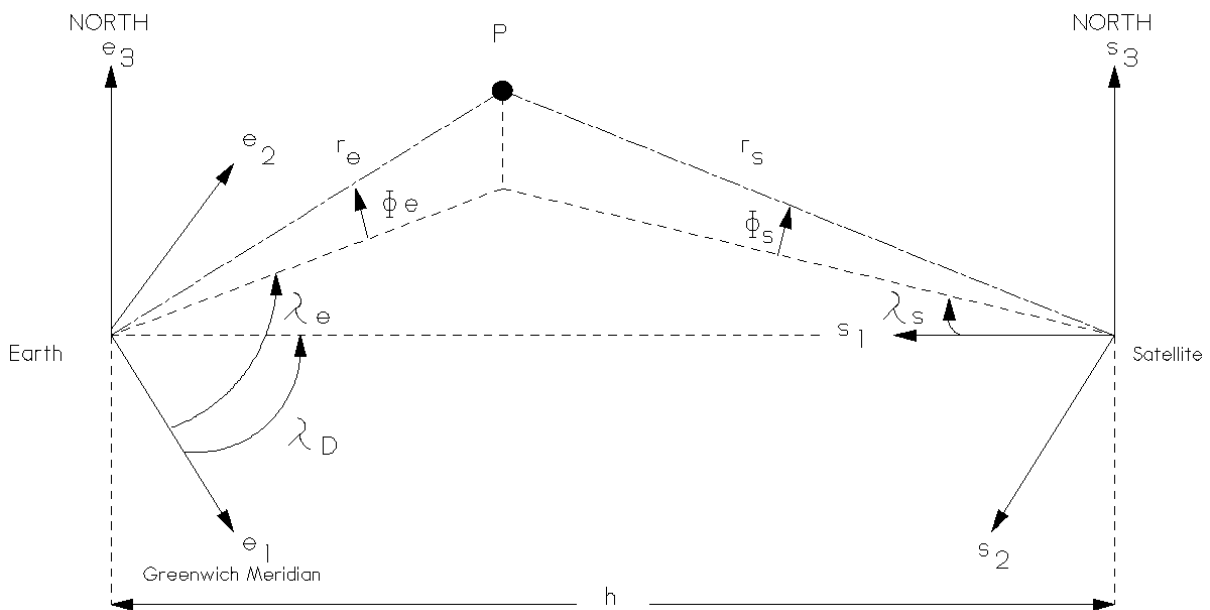

Figure 4-7 Coordinate Frames for GEOS Projection

The length of r_e is:

$$r_e = \frac{r_{pol}}{\sqrt{1 - \frac{r_{eq}^2 - r_{pol}^2}{r_{eq}^2} \cdot \cos^2(\phi_e)}}$$

Coordination Group for Meteorological Satellites	LRIT/HRIT Global Specification	CGMS
		Doc. No. : CGMS 03 Issue : 2.6 Date : 9 July 1999

The cartesian components of the vector r_s (in the satellite coordinate frame) result as follows:

$$\begin{pmatrix} r_1 \\ r_2 \\ r_3 \end{pmatrix} = \begin{pmatrix} h - r_e \cdot \cos(\phi_e) \cdot \cos(\lambda_e - \lambda_D) \\ -r_e \cdot \cos(\phi_e) \cdot \sin(\lambda_e - \lambda_D) \\ r_e \cdot \sin(\phi_e) \end{pmatrix}$$

$$h = 42164 \text{ km}$$

$$\lambda_D = \text{sub_lon}$$

From the above equations the satellite scanning angles can be derived:

$$\lambda_s = \arctan\left(\frac{r_2}{r_1}\right)$$

$$\phi_s = \arcsin\left(\frac{r_3}{\sqrt{r_1^2 + r_2^2 + r_3^2}}\right)$$

This completes the description of the theoretical background. In the following the specifications relevant for LRIT/HRIT are provided.

The (forward) projection function is as follows:

$$\begin{pmatrix} x \\ y \end{pmatrix} = \begin{pmatrix} \arctan\left(\frac{-r_2}{r_1}\right) \\ \arcsin\left(\frac{-r_3}{r_n}\right) \end{pmatrix}$$

Therein the variables r_1, r_2, r_3, r_n (and the auxiliary variables r_1 and c_lat are used to define them) are as follows:

$$r_1 = 42164 - r_l \cdot \cos(c_lat) \cdot \cos(lon - sub_lon)$$

$$r_2 = -r_l \cdot \cos(c_lat) \cdot \sin(lon - sub_lon)$$

$$r_3 = r_l \cdot \sin(c_lat)$$

$$r_n = \sqrt{r_1^2 + r_2^2 + r_3^2}$$

$$r_l = \frac{6356.5838}{\sqrt{1 - 0.00675701 \cdot \cos^2(c_lat)}}$$

$$c_lat = \arctan(0.993243 \cdot \tan(lat))$$

Coordination Group for Meteorological Satellites	LRIT/HRIT Global Specification	CGMS
		Doc. No. : CGMS 03 Issue : 2.6 Date : 9 July 1999

The inverse projection function is as follows:

$$\begin{pmatrix} lon \\ lat \end{pmatrix} = \begin{pmatrix} \arctan\left(\frac{s_2}{s_1}\right) + sub_lon \\ \arctan\left(1.006803 \cdot \frac{s_3}{s_{xy}}\right) \end{pmatrix}$$

Therein the variables s_1 , s_2 , s_3 , s_{xy} (and the auxiliary variables s_n and s_d used to define them) are as follows:

$$\begin{aligned} s_1 &= 42164 - s_n \cdot \cos(x) \cdot \cos(y) \\ s_2 &= s_n \cdot \sin(x) \cdot \cos(y) \\ s_3 &= -s_n \cdot \sin(y) \\ s_{xy} &= \sqrt{s_1^2 + s_2^2} \\ s_n &= \frac{42164 \cdot \cos(x) \cdot \cos(y) - s_d}{\cos^2(y) + 1.006803 \cdot \sin^2(y)} \\ s_d &= \sqrt{(42164 \cdot \cos(x) \cdot \cos(y))^2 - (\cos^2(y) + 1.006803 \cdot \sin^2(y)) \cdot 1737121856} \end{aligned}$$

Note that all trigonometric functions shall assume angles in degree, even for x and y.

Figure 4-8 shows a grid of geographical coordinates in normalized geostationary projection.

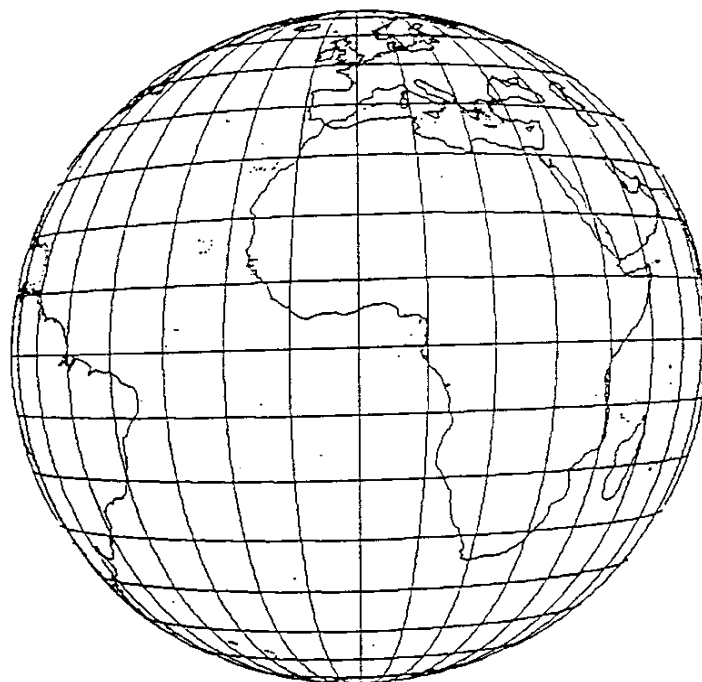

Figure 4-8 Normalized Geostationary Projection

Coordination Group for Meteorological Satellites	LRIT/HRIT Global Specification	CGMS
		Doc. No. : CGMS 03 Issue : 2.6 Date : 9 July 1999

4.4.3.3 Polarstereographic Projection

The projection name string shall be specified as

$$\text{POLAR}(\langle \text{prj_dir} \rangle, \langle \text{prj_lon} \rangle)$$

where $\langle \text{prj_dir} \rangle$ specifies the projection plane and $\langle \text{prj_lon} \rangle$ the central longitude.

$\langle \text{prj_dir} \rangle$ can be either N or S denoting north polar stereographic projection (i.e. the north pole is the centre of the projection plane) or south polar stereographic projection (i.e. the south pole is the centre of the projection plane).

$\langle \text{prj_lon} \rangle$ can be any integer or real between -180 and +180, specifying the central longitude in degree.

The projection functions are as follows:

With help of the auxiliary parameter

$$d := \begin{cases} +1 & \text{if } \text{prj_dir} = N \\ -1 & \text{else (if } \text{prj_dir} = S) \end{cases}$$

the (forward) projection function is

$$\begin{pmatrix} x \\ y \end{pmatrix} = \tan\left(\frac{90^\circ - d \cdot \text{lat}}{2}\right) \cdot \begin{pmatrix} \sin(\text{lon} - \text{prj_lon}) \\ \cos(\text{lon} - \text{prj_lon}) \end{pmatrix}$$

and thus its inversion is

$$\begin{pmatrix} \text{lon} \\ \text{lat} \end{pmatrix} = \begin{pmatrix} \arctan\left(\frac{x}{y}\right) + \text{prj_lon} + d \cdot 90^\circ \cdot (1 - \text{sgn}(y)) \\ d \cdot \left[90^\circ - 2 \cdot \arctan\left(\sqrt{x^2 + y^2}\right) \right] \end{pmatrix}$$

Polarstereographic projection is based on a spherical model of the earth.

Figure 4-9 shows a grid of geographical coordinates in polarstereographic projection.

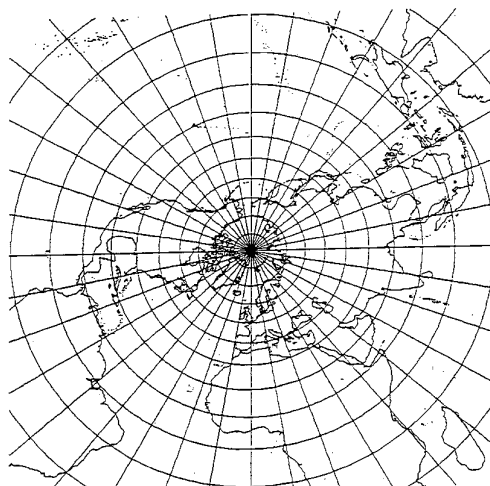

Figure 4-9 Polarstereographic Projection

Coordination Group for Meteorological Satellites	LRIT/HRIT Global Specification	CGMS
		Doc. No. : CGMS 03 Issue : 2.6 Date : 9 July 1999

4.4.3.4 Mercator Projection

The projection name shall be

MERCATOR

without any further parameter.

The projection functions are as follows:

$$\begin{pmatrix} x \\ y \end{pmatrix} = \begin{pmatrix} \frac{lon}{180^\circ} \\ \frac{1}{\pi} \cdot \ln \left[\tan \left(\frac{90^\circ - lat}{2} \right) \right] \end{pmatrix}$$

$$\begin{pmatrix} lon \\ lat \end{pmatrix} = \begin{pmatrix} x \cdot 180^\circ \\ 90^\circ - 2 \cdot \arctan(e^{\pi \cdot y}) \end{pmatrix}$$

Mercator projection is based on a spherical model of the earth.

Figure 4-10 shows a grid of geographical coordinates in Mercator projection.

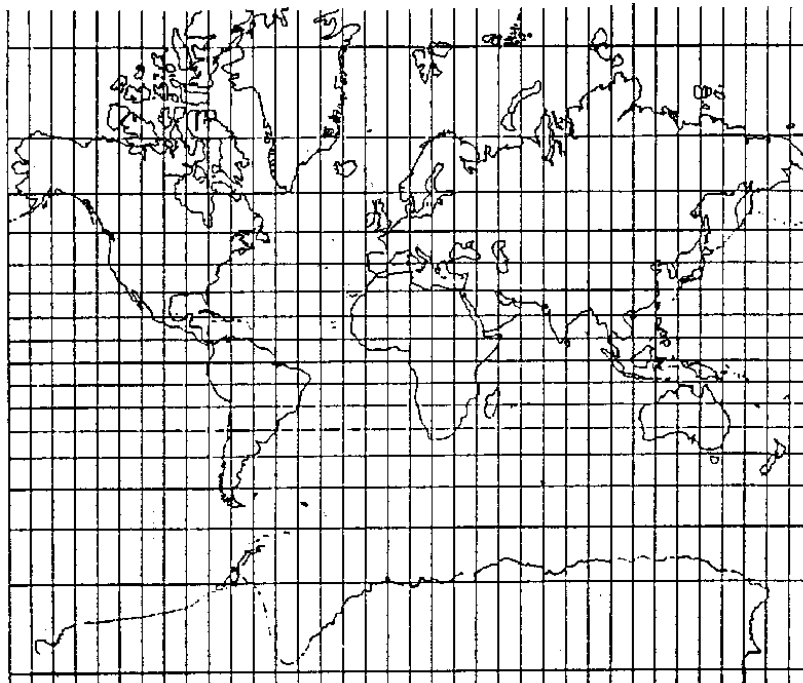

Figure 4-10 Mercator Projection

Coordination Group for Meteorological Satellites	LRIT/HRIT Global Specification	CGMS
		Doc. No. : CGMS 03 Issue : 2.6 Date : 9 July 1999

4.4.4 Scaling Function

The scaling function provides a linear relation between the intermediate coordinates (x,y) and the image coordinates (c,l).

The definition is as follows:

$$c = COFF + nint(x \cdot 2^{-16} \cdot CFAC)$$

$$l = LOFF + nint(y \cdot 2^{-16} \cdot LFAC)$$

Herein, "nint" denotes a nearest integer rounding of the real argument. COFF, CFAC, LOFF, LFAC are the (integer) scaling coefficients provided with the image navigation record. Each of the coefficients may have an integer value between -2^{31} and $+2^{31}-1$.

For the common orientation of the image both CFAC shall be positive. In order to support near real-time transmission of image data scanned from south to north LFAC may be selected negative.

Coordination Group for Meteorological Satellites	LRIT/HRIT Global Specification	CGMS
		Doc. No. : CGMS 03 Issue : 2.6 Date : 9 July 1999

5. SESSION LAYER

5.1 General

The session layer provide means for interchange of data useable for presentation. Main approach of the session layer for LRIT/HRIT is to perform compression and encryption of data, and the complementary transformations.

The session layer interfaces to the transport layer and to the presentation layer. Both service data unit and protocol data unit is one LRIT/HRIT file as defined in section 4.2. Consequently session services modify LRIT/HRIT files.

Contents and length of the data field may be changed upon session layer processing. Header records must not be affected by RX processing (i.e. decryption and decompression). If stringent timeliness requirements on file level shall be applied rather than making use of the priority scheme specified as part of the transport layer, the TX processing can optionally include a data sequencing function.

5.2 Encryption

All types of LRIT/HRIT files can be encrypted. The encryption method and the key distribution scheme are **mission specific**. However, the following global baseline shall be kept:

- Information required by authorised users for decrypting a file (e.g. key number) shall be included in a key header record, identified by header type 7.
- In case of key distribution via the mission LRIT/HRIT file type 3 (encryption key message) shall be used for this purpose.

5.3 Compression

Compression may be applied to LRIT/HRIT image data files (file type 0) only.

The compression flag in the image structure record (refer to section 4.2.2.1) determines whether the file's data field contains "clear" image data or a compressed data format: If the compression flag is nonzero then compression is selected.

Upon compression, the data field of the LRIT/HRIT image data file is substituted by the compressed data format. For the user's convenience, the compression flag codes whether lossless (compression flag = 1) or lossy (compression flag = 2) compression is applied.

As far as possible, the compression methods specified in ISO standard 10918 (commonly known as "JPEG" standard) shall be applied.

The selection of a subset of the methods offered by the JPEG standard, is **mission specific**.

The implementation of other compression methods than JPEG is **mission specific**.

Other compression methods than JPEG have to be identified via mission specific headers.

Coordination Group for Meteorological Satellites	LRIT/HRIT Global Specification	CGMS
		Doc. No. : CGMS 03 Issue : 2.6 Date : 9 July 1999

5.4 Data Sequencing Function

For mission specific reasons, preference may be given to a data sequencing function on LRIT/HRIT file level rather than priority schemes applicable to data units on lower communication layers.

E.g., the compressed and/or encrypted LRIT/HRIT files can put into a data sequence which is based on timeliness requirements defined per file type and other parameters directly derived from the file headers. Files exceeding certain criteria could then be removed from the data sequencer buffer.

The data sequencing operates independently from the priority scheme defined in sections 5.5 and 6.2.

The implementation of such method is **mission specific**.

5.5 Transmission Service Specification

5.5.1 Syntax

The session layer is called by the presentation layer in order to send out a file:

```
SESSION.request (S_SDU,PRIO)
```

The service data unit is an LRIT/HRIT file. The transmission priority (PRIO) is an input to the service as well. Values between 1 (lowest) and 63 (highest) are permitted. Additional parameters may be required as inputs to the service to select compression parameters, if the mission supports more than one set of parameters for one compression type (lossless or lossy) and if these are user selectable.

5.5.2 Function

At first the service scans the file, if it is an image data file, for an image structure record. If such record is present and if the compression flag is nonzero, then the requested compression is performed on the data field contents. The primary header is modified accordingly (data field length).

Then the file is scanned for a key header record. If such record is found then the encryption is performed on the data field contents.

After having performed the foregoing functions the resulting file (S_PDU) is submitted to the transport layer:

```
TRANSPORT.request (S_PDU, PRIO)
```

Coordination Group for Meteorological Satellites	LRIT/HRIT Global Specification	CGMS
		Doc. No. : CGMS 03 Issue : 2.6 Date : 9 July 1999

5.6 Reception Service Specification

5.6.1 Syntax

The session layer indicates towards the presentation layer the acquisition of one LRIT/HRIT file:

SESSION.indication (S_SDU)

The service data unit (S_SDU) is an output of the service, it contains the acquired LRIT/HRIT file, which has been decrypted and decompressed (if required).

5.6.2 Function

The transport layer indicates acquisition of a file by the primitive

TRANSPORT.indication (S_PDU).

The protocol data unit (S_PDU) is an LRIT/HRIT file, eventually encrypted and/or compressed. The S_PDU is scanned for a key header record first. If such record is found then the data field of the file is decrypted.

After that the file, if it is an image data file, is scanned for an image structure record. If the compression flag is nonzero, then the data field is decompressed and the primary header corrected accordingly (data field length).

The resulting file is the service data unit (S_SDU) forwarded to the presentation layer.

Coordination Group for Meteorological Satellites	LRIT/HRIT Global Specification	CGMS
		Doc. No. : CGMS 03 Issue : 2.6 Date : 9 July 1999

6. TRANSPORT LAYER

6.1 General

The transport layer provides means for transparent transfer of data between session entities. It provides towards its user, the session layer, a service to transport a file. The transport service data unit (TP_SDU) is a variable length file.

Upon sending one file the TP_SDU has to be accompanied by the intended priority TP_PRIO (1... 63). The TP_SDU is a variable length data structure. Within the transport service the file is filled up to an octet-aligned length, if necessary. Then the file is segmented and each segment is added up with a CRC error control field. The result is inserted into CCSDS packets, which can be forwarded to the network layer. The APID is internally calculated, depending on the priority and on the APIDs used by other open files having the same priority.

Upon reception of a file the reconstructed TP_SDU is forwarded to the session layer.

6.2 Transmission Service Specification

6.2.1 Syntax

The transport layer is called by the session layer in order to send out a file:

TRANSPORT.request (TP_SDU, PRIO)

The service data unit (TP_SDU) is a variable length file (1 ... (2⁶⁴-1) bit). The transmission priority (PRIO) is an input to the service as well. Values between 1 (lowest) and 63 (highest) are permitted.

6.2.2 Function

At first the service attempts to allocate an unused APID within the permitted range, which depends on the selected priority:

lowest APID = 2016 - 32·PRIO

highest APID = 2047 - 32·PRIO

If this is not possible then the service request is queued until one APID becomes free. The transport file is generated by concatenating a 80 bit transport header, the TP_SDU contents, and a filler block (0 ... 7 bit) required to fill up the last octet. The transport header contains a 16 bit file counter and a 64 bit length field specifying the length of the TP_SDU in bits (1 ... 2⁶⁴-1). The file counter is incremented by 1 (modulo 2¹⁶) with each transport request. Figure 6-1 shows the transport file.

The transport file is split up into one or more blocks of 8190 octets size, except the last block which may contain 1 ... 8190 octets. Each block gets a 16 bit CRC error control field at its end, resulting in segments of up to 8192 octets size. This checksum is computed over the entire block. The generator polynomial is

$$g(x) = x^{16} + x^{12} + x^5 + 1.$$

Both encoder and decoder shall be initialized to "all ones" for each block.

Coordination Group for Meteorological Satellites	LRIT/HRIT Global Specification	CGMS
		Doc. No. : CGMS 03 Issue : 2.6 Date : 9 July 1999

For each segment, in order, a source packet is generated. The user data field of each source packet receives one segment. The secondary header flag in the packet header is set with the first segment only. Refer to section 7.1 for more details on the source packet structure.

Each source packet is forwarded to the network layer by means of the primitive

PACKET.request (TP_PDU)

where TP_PDU denotes the protocol data unit of the transport layer (which is the source packet).

Coordination Group for Meteorological Satellites	LRIT/HRIT Global Specification	CGMS
		Doc. No. : CGMS 03 Issue : 2.6 Date : 9 July 1999

6.3 Reception Service Specification

6.3.1 Syntax

The transport layer indicates towards the session layer the acquisition of one LRIT/HRIT file:

TRANSPORT.indication (TP_SDU)

The service data unit (TP_SDU) is an output of the service, it contains the acquired LRIT/HRIT file.

6.3.2 Function

Upon acquisition of source packets, indicated by the network layer primitive

PACKET.indication (TP_PDU)

the packets are sorted for their APIDs. The contents of the user data fields, except the last two octets (which include the CRC field) are concatenated under control of the sequence flags in the packet headers, resulting in a transport file. As soon as a transport file is complete, the TP_SDU is extracted (see Figure 6-1) and routed to the session layer.

6.3.3 Optional Functionality

Although the functions outlined in section 6.3.2 make up a basic functionality, some more features may be added for improved performance and reliability:

- a) The CRC field included in each segment can be used to quote the integrity of received data.
- b) Completeness of data can be verified with help of the packet sequence count (included in the packet header) and with help of the length field in the transport header.
- c) Logging and monitoring of reception service functions may be helpful. The contents of the file counters included in the transport headers may be used to provide a simple means to verify the continuous functionality on basis of log information.
- d) Unexpected information retrieved from incoming packet headers, probably caused by bit errors therein, may be corrected by means of redundancy (e.g. implied by sequence) and semantics.

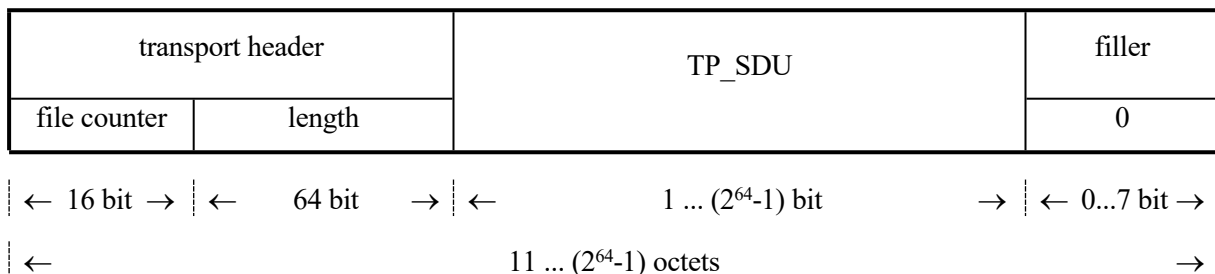

Figure 6-1 Transport File Structure

Coordination Group for Meteorological Satellites	LRIT/HRIT Global Specification	CGMS
		Doc. No. : CGMS 03 Issue : 2.6 Date : 9 July 1999

7. NETWORK LAYER

7.1 General

The network layer is represented by the path layer defined for CCSDS advanced orbiting systems.

The path layer provides a single service, the so-called packet service, to its user, the transport layer. The packet service uses the multiplexing service of the VCLC sublayer at the top of the data link layer.

The CCSDS path service data unit (CP_SDU) is directly forwarded through the network layer as CCSDS path protocol data unit (CP_PDU). There is no internal processing on the CP_SDUs inside the path layer. In fact the only function of the path layer is to generate the correct VCDU-IDs upon forwarding CP_PDUs to the multiplexing service on the transmitting side of the communication link.

There is no separate path id to be specified when forwarding CP_SDUs into the path layer. The application process identifier (APID) included in the CP_SDU is used as path id.

Figure 7-1 shows the CP_PDU structure. It consists of a packet header (6 octets in length) and a variable length, octet aligned, user data field. This user data field is limited to 8192 octets in length, it contains a segment of a user data file.

Coordination Group for Meteorological Satellites	LRIT/HRIT Global Specification	CGMS
		Doc. No. : CGMS 03 Issue : 2.6 Date : 9 July 1999

The elements of the packet header are as follows:

version	set to 0 to specify version-1 CCSDS packet
type	set to 0, irrelevant for AOS
secondary header flag	set to 1 if the user data begins with a header field (this is the case if sequence flags equals to one or three); set to 0 else
APID	set to 0 ... 2015, specifying the logical data path and implicitly the link priority (see explanations in 7.2.2)
sequence flags	set to 3 if the user data contains one user data file entirely; set to 1 if the user data contains the first segment of one user data file extending through subsequent packet(s); set to 0 if the user data contains a continuation segment of one user data file still extending through subsequent packet(s); set to 2 if the user data contains the last segment of a user data file beginning in an earlier packet.
packet sequence counter	sequential count modulo 16384, numbering the packets on the specified logical data path specified by the APID.
packet length	number of octets in the user data field minus 1. Since the length of the user data field may vary between 1 and 8192 octets, the packet length field may be set to a value between 0 and 8191.

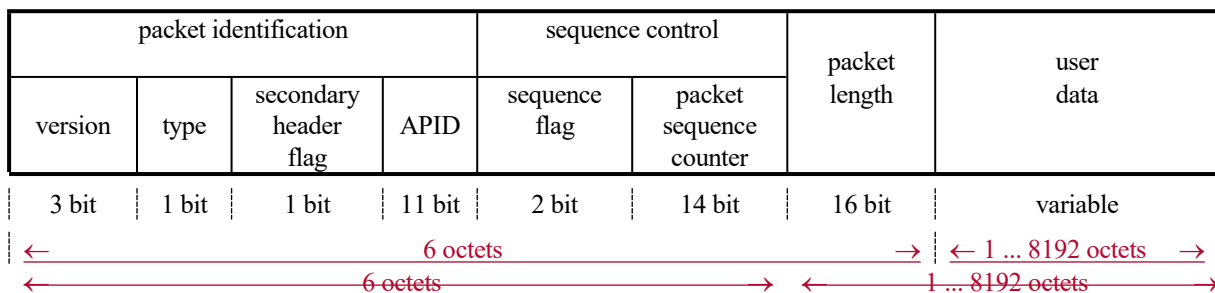

Figure 7-1 CP_PDU Structure

Coordination Group for Meteorological Satellites	LRIT/HRIT Global Specification	CGMS
		Doc. No. : CGMS 03 Issue : 2.6 Date : 9 July 1999

7.2 Transmission Service Specification

7.2.1 AOS Syntax

The network layer service is called by the transport layer service in order to send out one source packet:

PACKET.request (CP_SDU)

The service data unit (CP_SDU) is an input to the service.

7.2.2 Function

The VCDU-ID is generated as follows:

The spacecraft id is set statically to mission specific value.

The virtual channel id is set to a value resulting from an integer division of APID by 32. Thus, APID 0 ... 31 are mapped to VC 0, APID 32 ... 63 to VC 1, ... , up to APID 1984 ... 2015 being mapped to VC 62. APID beyond 2015 must not be used with LRIT/HRIT. The user (i.e. the transport layer) is therefore capable of handling up to 2016 parallel packet streams, while groups of 32 each have the same priority on the link. With increasing APID the priority decreases. Refer to the description of the VCA sublayer for a description on how the virtual channel id affects the priority of the VC on the link.

After having determined the VCDU-ID the service calls the data link layer transmission service as

M_UNITDATA.request (CP_PDU, VCDU-ID)

with CP_PDU = CP_SDU defining the multiplexing service data unit. Both parameters are input to the multiplexing service.

7.3 Reception Service Specification

7.3.1 AOS Syntax

The network layer service indicates towards the transport layer service of the addressed application the acquisition of a source packet:

PACKET.indication (CP_SDU)

The service data unit (CP_SDU) is an output of the service. The application is implicitly determined by means of the application process identifier (APID) contained in the header of the source packet.

7.3.2 Function

Upon acquisition of a source packet, indicated by the data link layer primitive

M_UNITDATA.indication (CP_PDU, VCDU-ID)

the service forwards the source packet (CP_SDU = CP_PDU) to the transport layer by means of the primitive

PACKET.indication (CP_SDU).

Coordination Group for Meteorological Satellites	LRIT/HRIT Global Specification	CGMS
		Doc. No. : CGMS 03 Issue : 2.6 Date : 9 July 1999

Optionally the function may check the (redundant) value of VCDU-ID by comparing it to the virtual channel number derived from the APID contained in the packet header and by validating the (known) spacecraft id.

Coordination Group for Meteorological Satellites	LRIT/HRIT Global Specification	CGMS
		Doc. No. : CGMS 03 Issue : 2.6 Date : 9 July 1999

8. DATA LINK LAYER

8.1 Overview

The data link layer is implemented by the space link layer of the space link subnetwork specified by CCSDS for advanced orbiting systems. It consists of two sublayers:

- virtual channel link control (VCLC) sublayer
- virtual channel access (VCA) sublayer

The VCLC sublayer receives CCSDS path protocol data units (CP_PDU) from the network layer as its service data unit, whereas the VCA sublayer forwards the physical channel access protocol data unit (PCA_PDU) to the physical layer (as its protocol data unit).

The data link layer provides by means of the VCLC sublayer the multiplexing service to its user, the network layer. There are no more services provided by the LRIT/HRIT data link layer. The data link layer requires the physical channel service from the physical layer only.

Figure 8-1 shows the overall configuration of the data link layer.

LRIT/HRIT is designed as a Grade-2 service, i.e. transmission will be error controlled using Reed-Solomon coding. Due to the non-availability of a duplex link there is no possibility of raising the service to Grade-1.

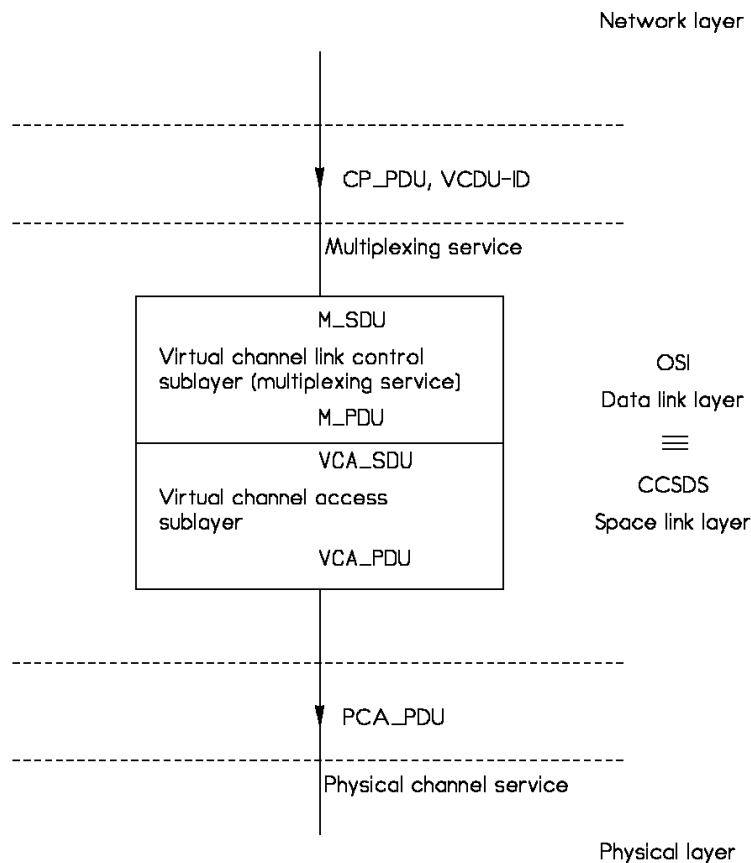

Figure 8-1 Data Link Layer

Coordination Group for Meteorological Satellites	LRIT/HRIT Global Specification	CGMS
		Doc. No. : CGMS 03 Issue : 2.6 Date : 9 July 1999

8.2 Virtual Channel Link Control Sublayer

8.2.1 General

The VCLC sublayer provides the multiplexing service only. Encapsulation and bitstream services are not supported.

The actual user of the service is the CCSDS path layer incorporated in the network layer. This user provides CP_PDUs as multiplexing service data units (M_SDU) for multiplexing them into multiplexing protocol data units (M_PDUs) and vice versa. With each M_SDU the virtual channel is addressed by its VCDU-ID. Data from various packet channels addressing the same VC may be multiplexed into one M_PDU.

The VCLC sublayer uses the virtual channel access service of the VCA sublayer, the generated M_PDUs are forwarded as VCA_SDUs together with the VCDU-ID.

While the number of parallel data streams at the VCLC_SAP are determined by the number of packet channels on all virtual channels, at the VCA_SAP there are remaining as many data streams as virtual channels are used.

Figure 8-2 shows the structure of the M_PDU. The total length of one M_PDU is 886 octets. It consists of a header (2 octets) and a packet zone (884 octets), into which the M_SDUs for the actual VC are inserted.

The components of the M_PDU header are defined as follows:

spare	for future use, set to all zero
first header pointer	contains a binary count P (0...2047) identifying the offset (in octets) between the begin of the M_PDU packet zone and the first M_SDU header (i.e. M_SDU #k in figure 10-2) therein. If the packet zone does not contain any M_SDU header at all (e.g. if a M_SDU spans over three or more M_PDUs) then P shall be set to all ones (i.e. 2047).

The M_PDU packet zone contains variable length M_SDUs, each of them being a CCSDS version-1 packet. The first and the last packet in the M_PDU zone are not necessarily complete. The M_PDU packet zone may contain a part of a single M_SDU only.

In case that a partly generated M_PDU cannot be completed since no more M_SDU is available for the related virtual channel, a fill packet is generated to complete the M_PDU, after a timeout is expired.

Figure 8-3 shows the structure of this fill packet. The packet length has to be determined in such way that the incomplete M_PDU gets filled up. Within the fill packet the packet length element specifies the size of the user data field in octets minus one. If the remaining spare in the incomplete M_PDU is less than seven octets then the fill packet is sized to fill the incomplete M_PDU plus one more M_PDU entirely.

Coordination Group for Meteorological Satellites	LRIT/HRIT Global Specification	CGMS
		Doc. No. : CGMS 03 Issue : 2.6 Date : 9 July 1999

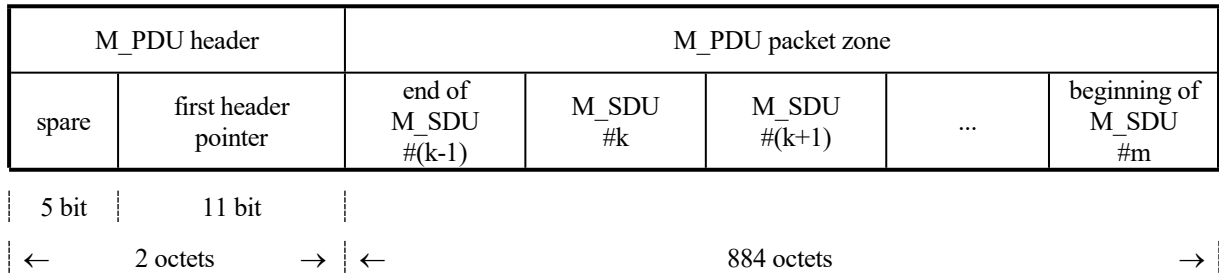

Figure 8-2 M_PDU Structure

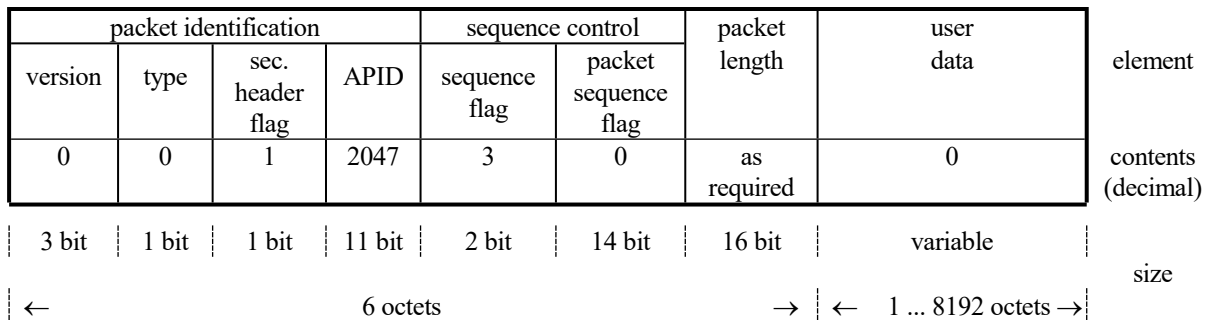

Figure 8-3 Fill Packet

8.2.2 Transmission Service Specification

8.2.2.1 AOS Syntax

The VCLC sublayer service is called by the network layer service in order to send out one source packet:

M_UNITDATA.request (M_SDU, VCDU-ID)

Both the service data unit and the VCDU-ID are inputs to the service.

8.2.2.2 Function

The service data unit is multiplexed into one or more M_PDUs, depending on the space in an eventually available incomplete M_PDU and on the size of the M_SDU. Incomplete M_PDUs belonging to other than the specified VC are not affected so far. As soon as an M_PDU is completed (this may occur zero or more times upon one M_UNITDATA.request service call) it is forwarded to the VCA sublayer service as

VCA_UNITDATA.request (M_PDU, VCDU-ID).

Additionally, as soon as an incomplete M_PDU of any VCDU-ID remains incomplete for more than three seconds (counted from the time the first source data was inserted into the incomplete M_PDU) a fill packet is generated for that virtual channel, causing one or two VCA requests (depending on the remaining space in the incomplete M_PDU).

Coordination Group for Meteorological Satellites	LRIT/HRIT Global Specification	CGMS
		Doc. No. : CGMS 03 Issue : 2.6 Date : 9 July 1999

8.2.3 Reception Service Specification

8.2.3.1 AOS Syntax

The VCLC sublayer service indicates towards the network layer service the acquisition of a source packet:

M_UNITDATA.indication (M_SDU, VCDU-ID)

The service provides both the service data unit and the VCDU-ID as output.

8.2.3.2 Function

Upon acquisition of an M_PDU, indicated by the VCA sublayer primitive

VCA_UNITDATA.indication (M_PDU, VCDU-ID)

the service demultiplexes zero or more source packets from the acquired M_PDU and eventually available buffered data belonging to the same virtual channel. Whenever a source packet is completed it is checked for being a fill packet: If the APID equals 2047 the packet is assumed to be a fill packet. Fill packets are discarded, whereas other source packets are forwarded to the network layer using the primitive

M_UNITDATA.indication (M_SDU, VCDU-ID).

Coordination Group for Meteorological Satellites	LRIT/HRIT Global Specification	CGMS
		Doc. No. : CGMS 03 Issue : 2.6 Date : 9 July 1999

8.3 Virtual Channel Access Sublayer

8.3.1 General

The VCA sublayer provides the virtual channel access service only. Both insert service and virtual channel data unit service are not used with the LRIT/HRIT application.

In fact the VCLC sublayer is the only user of the VCA service, the VCA_SDU is the M_PDU. Each VCA_SDU is accompanied by a corresponding VCDU-ID specifying the related VC. Since LRIT/HRIT is a Grade-2 service, the VCA sublayer incorporates virtual channel procedures and channel access procedures only. Slap procedures are not supported at all.

The VCA sublayer generates and retrieves the virtual channel access protocol data unit (VCA_PDU), which is the serial bitstream forwarded to and acquired from the physical layer. The VCA sublayer uses the physical channel service as it is provided by the physical layer.

The virtual channel procedures are in fact functions required to generate virtual channel data units (VCDUs) from VCA_SDUs and vice versa. One of the channel access procedures is to handle Reed-Solomon check symbols. A VCDU with attached check symbols is called coded virtual channel data unit (CVCDU). The structure of one CVCDU is shown in Figure 8-4.

The elements of the CVCDU are as follows:

VCDU primary header	contains a six octets header structure as shown in Figure 8-5 and as described below
VCDU data unit zone	contains one VCA_SDU in case of a valid VCDU or all zeros in case of a fill VCDU
Reed-Solomon check symbols	contain Reed-Solomon code (255,223) encoded check symbols, calculated over the VCDU primary header and the VCDU data unit zone, as specified in [AD.5].

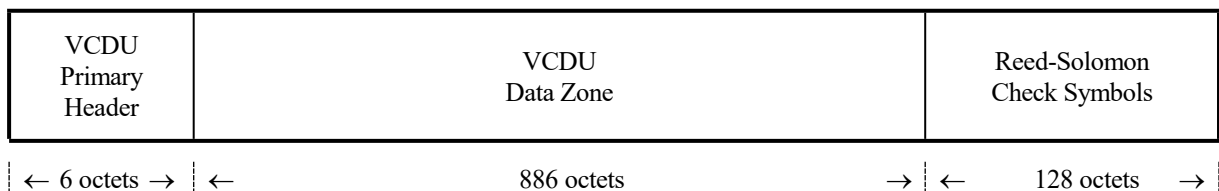

Figure 8-4 CVCDU Structure

Coordination Group for Meteorological Satellites	LRIT/HRIT Global Specification	CGMS
		Doc. No. : CGMS 03 Issue : 2.6 Date : 9 July 1999

The VCDU primary header shown in Figure 8-5 consists of the following elements:

version number	set to 1 specifying version-2 CCSDS structure
VCDU-ID	virtual channel data unit identifier as specified by higher layers, consisting of spacecraft identifier and virtual channel identifier, set to 63 for fill VCDUs
VCDU counter	sequential count (modulo 16777216) of VCDUs on each virtual channel
signalling field/replay flag	set to 0 specifying real-time VCDUs

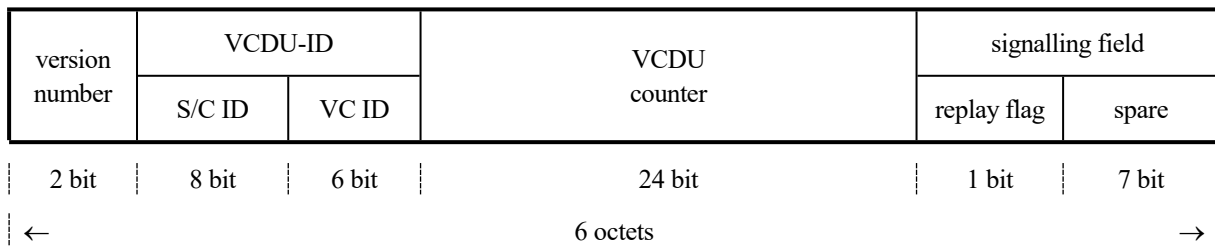

Figure 8-5 VCDU Primary Header

8.3.2 Transmission Service Specification

8.3.2.1 AOS Syntax

The VCA sublayer service is called by the VCLC sublayer service to send out one M_PDU:

VCA_UNITDATA.request (VCA_SDU, VCDU-ID)

Both the service data unit (being one M_PDU) and the VCDU-ID are inputs to the service.

8.3.2.2 Function

Figure 8-6 provides an overview of the transmission service. At first a CVCDU is generated: The primary header is constructed with help of the VCDU-ID provided with the request. The updated VCDU counter is saved for next use with the same VC. The data unit zone receives the service data unit. The Reed-Solomon check symbols are calculated as specified in section 8.3.1. Separate queues for CVCDUs of all supported virtual channels (0 ... 63) are available for receiving generated CVCDUs.

CVCDUs for various VCs are commutated into a single sequence. Upon commutation a strong priority concept is executed, decreasing the VC priority with increasing VC identifier value. As long as CVCDUs for VC 0 are available, only these are inserted into the dissemination stream. As soon as no more CVCDUs are available for VC n, the queue for VC (n+1) is polled. At the end, if no CVCDUs at all are available, fill CVCDUs (i.e. CVCDUs with VC 63 and all zero data) are inserted.

Coordination Group for Meteorological Satellites	LRIT/HRIT Global Specification	CGMS
		Doc. No. : CGMS 03 Issue : 2.6 Date : 9 July 1999

The commutated sequence of CVCDUs is converted into a sequence of channel access data units (CADUs). For this purpose each CVCDU is randomized first and preceded by a synchronization marker then.

Randomization is performed by multiplying all 8160 bits of the CVCDU with a statically defined pseudonoise pattern. The pseudonoise sequence is generated by means of the following polynomial:

$$h(x) = x^8 + x^7 + x^5 + x^3 + 1$$

This sequence repeats after 255 bits and the sequence generator has to be started from an all-ones state. The resulting PN pattern begins with (hexadecimal) FF480EC09A... .

The synchronization marker is defined to be (hexadecimal)

1ACFFC1D

which describes a 32 bit pattern to precede each CVCDU.

The resulting CADU sequence is serialized at a bit determined by the physical layer. Each CADU has a length of 8192 bits.

The serial bitstream is forwarded to the physical layer for transmission.

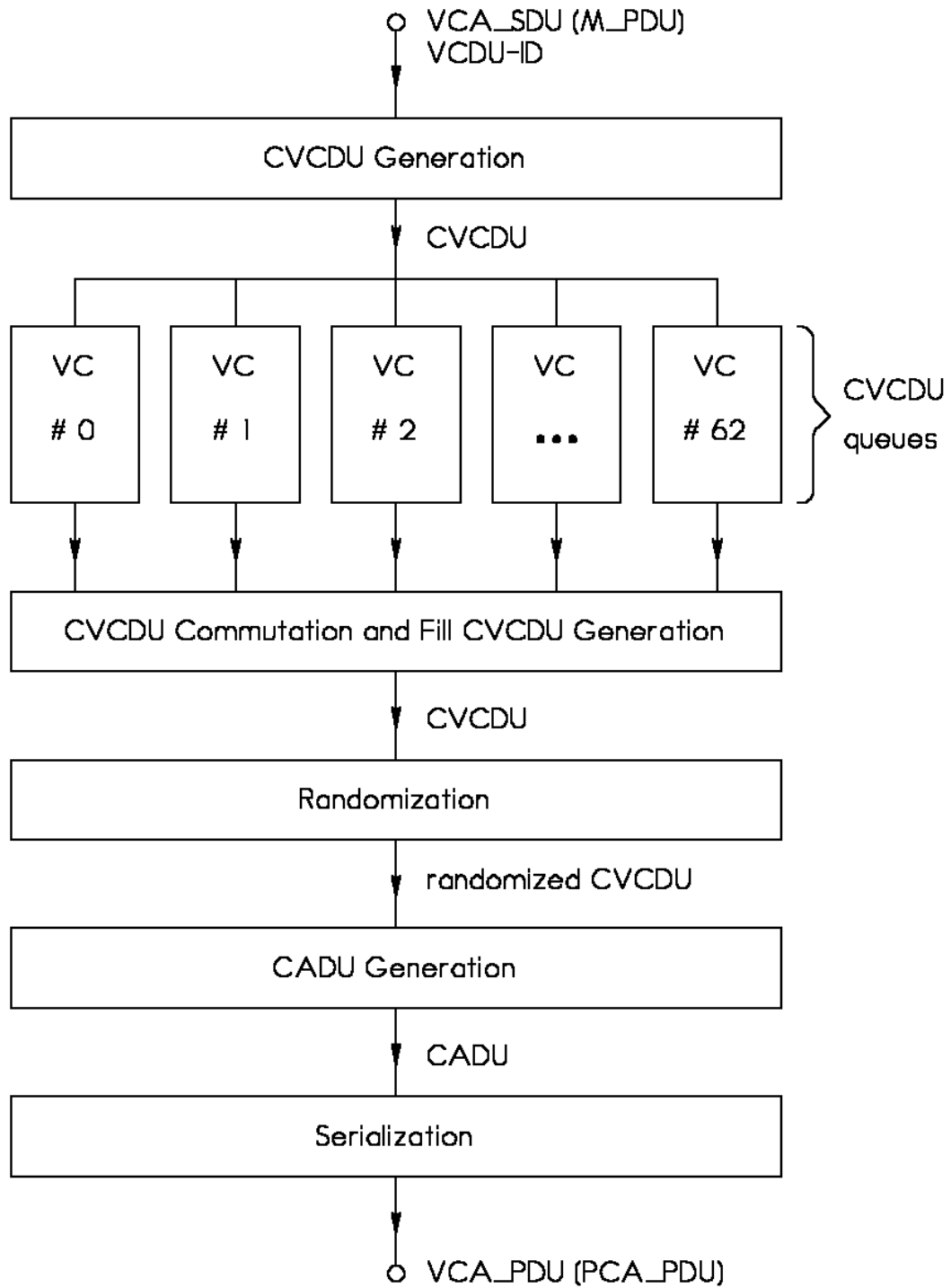

Figure 8-6 VCA Transmission Service

Coordination Group for Meteorological Satellites	LRIT/HRIT Global Specification	CGMS
		Doc. No. : CGMS 03 Issue : 2.6 Date : 9 July 1999

8.3.3 Reception Service Specification

8.3.3.1 AOS Syntax

The VCA sublayer service indicates towards the VCLC sublayer the acquisition of a M_PDU:

VCA_UNITDATA.indication (VCA_SDU, VCDU-ID).

The service provides both the service data unit (being one M_PDU) and the VCDU-ID as output.

8.3.3.2 Function

Figure 8-7 provides an overview of the reception service. The incoming serial datastream (VCA_PDU) is synchronized into discrete CADUs. After this frame synchronization process one (randomized) CVCDU is extracted from each CADU by means of stripping the synchronization markers off. Derandomization is performed then by multiplying all 8160 bits of the randomized CVCDU with a statically defined pseudonoise pattern. The synchronization marker and the randomization pattern are specified in section 8.3.2.2. After derandomization each "clear" CVCDU undergoes a forward error correction based on the Reed-Solomon check symbols included therein (details are provided in [AD.5]). Optionally the forward error correction may be omitted, requiring an increased performance of the physical layer (e.g. a bigger antenna) to compensate the FEC gain.

After forward error correction fill VCDUs (those with VC = 63) are discarded. The VCA_SDU is extracted from the data unit zone of the VCDU, the VCDU-ID is defined in the primary header. Indication towards the VCLC sublayer is performed by means of the primitive

VCA_UNITDATA.indication (VCA_SDU, VCDU-ID).

8.3.3.3 Optional Functionality

Several optional features may be implemented in the VCA reception service. Here are some examples:

- a) Status and quality of CADU synchronization can be monitored.
- b) Fill VCDUs can be analyzed for bit errors before and/or after forward error correction in order to monitor the performance of the physical link and the performance of the FEC with the actual noise situation.
- c) The VCDU counters can be traced to detect any discontinuity in the VCDU sequence.

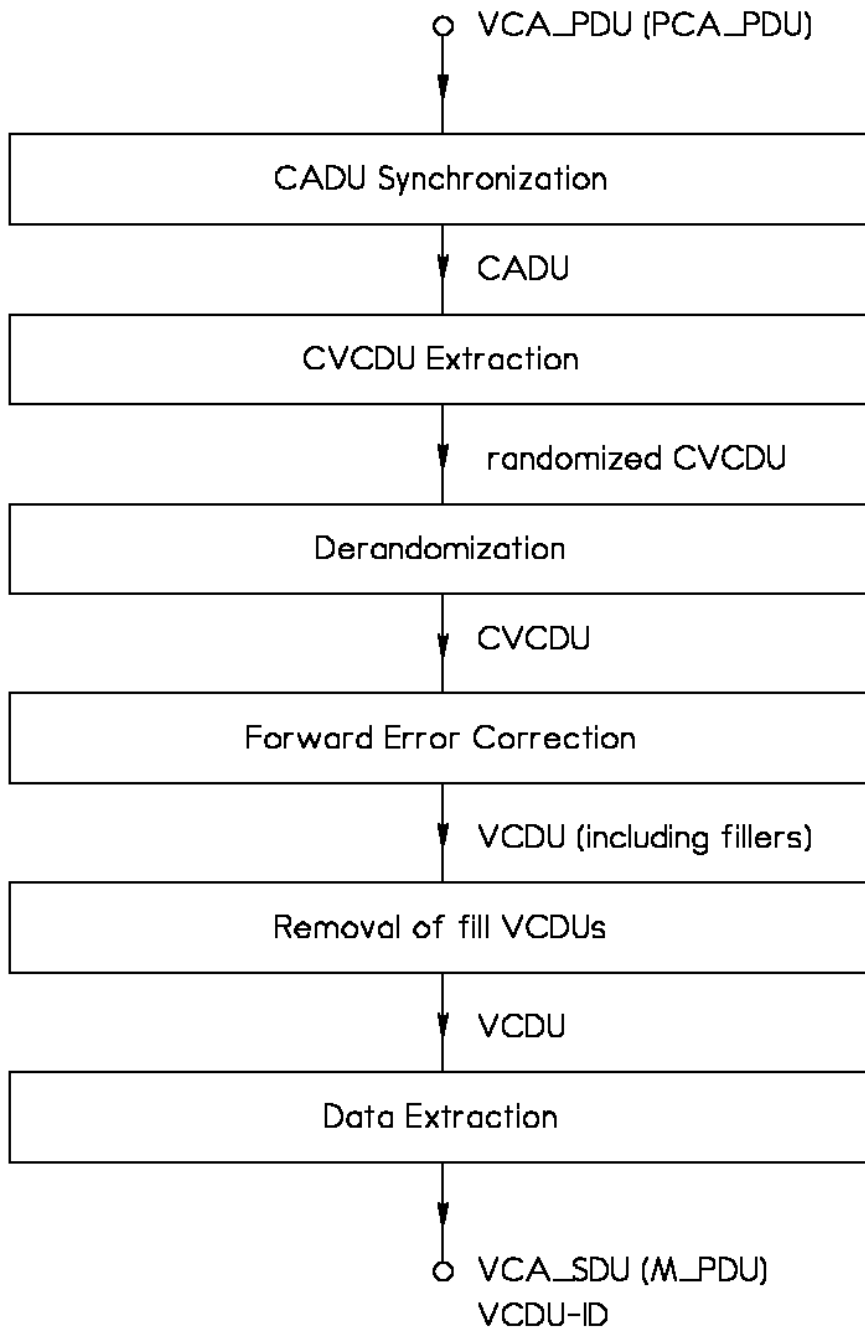

Figure 8-7 VCA Reception Service

Coordination Group for Meteorological Satellites	LRIT/HRIT Global Specification	CGMS
		Doc. No. : CGMS 03 Issue : 2.6 Date : 9 July 1999

9. PHYSICAL LAYER

The physical layer provides the physical channel service. The service data unit is a serial bitstream. The PCA_PDU is passed from the data link layer to the physical layer on the transmitting side and vice versa on the receiving side.

The performance of the physical layer shall be sufficient to ensure a remaining bit error rate not exceeding 10^{-8} after applying the forward error correction. The procedure for applying the FEC is described in section 8.3.3.2 while the algorithm is specified in [AD.5]. One can expect a FEC gain of 4.6 dB for Gaussian channel noise.

The use of concatenated coding i.e. the FEC described in sect. 8.3.3.2 (Reed-Solomon coding) together with any type of convolutional code is **mission specific**.

The data rate provided by the physical channel determines the mission name, as already indicated in section 1.5:

- If the data rate is less than 256 kbit/s then the mission is named LRIT.
- If the data rate is greater than or equal 256 kbit/s then the mission is named HRIT.

The implementation of the physical channel is **mission specific**.

Coordination Group for Meteorological Satellites	LRIT/HRIT Global Specification	CGMS
		Doc. No. : CGMS 03 Issue : 2.6 Date : 9 July 1999

APPENDIX A - LIST OF ABBREVIATIONS

Acronym	Meaning
AOS	Advanced orbiting systems
APID	Application process identifier
ASCII	American standard code for information interchange
CADU	Channel access data unit
CCSDS	Consultative Committee for Space Data Systems
CP_PDU	CCSDS path protocol data unit
CP_SDU	CCSDS path service data unit
CRC	Cyclic redundancy check
CVCDU	Coded virtual channel data unit
DCT	Discrete cosine transformation
EIRP	Equivalent isotropic radiance power
ESA	European Space Agency
FEC	Forward error correction
GTS	Global Telecommunication System
G/T	Figure of merit
HRIT	High Rate Information Transmission
HRUS	HRIT User Station
ISO	International Organisation for Standardisation
JPEG	Joint Photographic Experts Group
LRIT	Low Rate Information Transmission
LRPT	Low Rate Picture Transmission
LRUS	LRIT User Station
LSB	Least significant bit
M_PDU	Multiplexing service protocol data unit
M_SDU	Multiplexing service data unit
MSB	Most significant bit
NASA	National Aeronautics and Space Administration
NOAA	National Oceanic and Atmospheric Administration
NRZ-L	Nonreturn-to-zero-Level
NRZ-M	Nonreturn-to-zero-Mark
OSI	Open systems interconnection
PC_SDU	Physical channel service data unit
PCA_PDU	Physical channel access protocol data unit
PN	Pseudonoise
RX	Reception
S/C	Spacecraft
SDU	Service data unit
S_PDU	Session protocol data unit
S_SDU	Session service data unit

Coordination Group for Meteorological Satellites	LRIT/HRIT Global Specification	CGMS
		Doc. No. : CGMS 03 Issue : 2.6 Date : 9 July 1999

TP_PDU	Transport protocol data unit
TP_PRIO	Transport priority
TP_SDU	Transport service data unit
TX	Transmission
UTC	Coordinated universal time
VC	Virtual channel
VC_PDU	Virtual channel protocol data unit
VCA	Virtual channel access
VCA_SAP	Virtual channel access service access point
VCA_SDU	Virtual channel access service data unit
VCDU	Virtual channel data unit
VCDU-ID	Virtual channel data unit identifier
VCLC	Virtual channel link control
VCLC_SAP	Virtual channel link control service access point
WEFAX	Weather Facsimile
WMO	World Meteorological Organisation

Coordination Group for Meteorological Satellites	LRIT/HRIT Global Specification	CGMS
		Doc. No. : CGMS 03 Issue : 2.6 Date : 9 July 1999

APPENDIX B - DATA TYPES

B.1 Unsigned Integer

An unsigned integer is a data structure of n bit length with n being a multiple of 8. Its value is determined by the binary representation of the bits therein, where the first bit is the MSB and the last is the LSB. The value ranges from 0 to 2^n-1 .

B.2 Signed Integer

A signed integer is a data structure of n bit length with n being a multiple of 8. The first bit is the MSB, the last bit is the LSB. With N being the (unsigned) binary representation of the bits therein, the value is determined as follows: If the MSB equals 0 then the value equals N . Else (i.e. MSB = 1) the value is $2^n - N$. Consequently the value ranges from -2^{n-1} to $2^{n-1}-1$.

B.3 Character

A character string consists of a sequence of one or more octets, each of them representing one character. The binary value of each octets determines the character, international alphabet no. 5 is used as code. Figure B-1 shows the code table, where the binary value is $N = 16 \times X + Y$. Note that values beyond 127 are not used.

B.4 CCSDS Time

Within LRIT/HRIT the CCSDS day segmented time code is used. The data structure is six octets in length, where the first two octets (16 bits) represent the day and the last four octets (32 bits) represent the ms of day. The day code epoch is 1-Jan-1958.

The preamble code (which is not transmitted) of the implemented code is 01000000 (binary).

Note that all date and time information is based on the UTC time scale.

Coordination Group for Meteorological Satellites	LRIT/HRIT Global Specification	CGMS
		Doc. No. : CGMS 03 Issue : 2.6 Date : 9 July 1999

		X							
		0	1	2	3	4	5	6	7
Y	0	<NUL>	<DLE>	<SP>	0	@	P	`	p
	1	<SOH>	<DC1>	!	1	A	Q	a	q
	2	<STX>	<DC2>	“	2	B	R	b	r
	3	<ETX>	<DC3>	#	3	C	S	c	s
	4	<EOT>	<DC4>	\$	4	D	T	d	t
	5	<ENQ>	<NAK>	%	5	E	U	e	u
	6	<ACK>	<SYN>	&	6	F	V	f	v
	7	<BEL>	<ETB>	'	7	G	W	g	w
	8	<BS>	<CAN>	(8	H	X	h	x
	9	<HT>)	9	I	Y	i	y
	A	<LF>	<SUB>	*	:	J	Z	j	z
	B	<VT>	<ESC>	+	;	K	[k	{
	C	<FF>	<IS4>	,	<	L	\	l	
	D	<CR>	<IS3>	-	=	M]	m	}
	E	<SO>	<IS2>	.	>	N	^	n	~
	F	<SI>	<IS1>	/	?	O	_	o	

Figure B-1 Character Code Table

Coordination Group for Meteorological Satellites	LRIT/HRIT Global Specification	CGMS
		Doc. No. : CGMS 03 Issue : 2.6 Date : 9 July 1999

APPENDIX C - LIST OF MISSION SPECIFIC ITEMS

Section	Item
3	Specification of the application layer
4.2	Mission specific file types (if any)
4.2	Mission specific header records (if any)
4.2.3.4	Details on encryption key message files (if used)
4.4.3	Mission specific projection functions (if any)
5.2	Details on encryption (if used)
5.3	Selection of JPEG compression method Selection of mission specific compression method
5.4	Data sequencing function
5.5	Usage of priorities
7.2.2	Spacecraft identifier
9	Specification of the physical layer

Note that any mission using this global LRIT/HRIT specification has to determine the above mentioned items. However, more information may be required to specify the mission sufficiently.